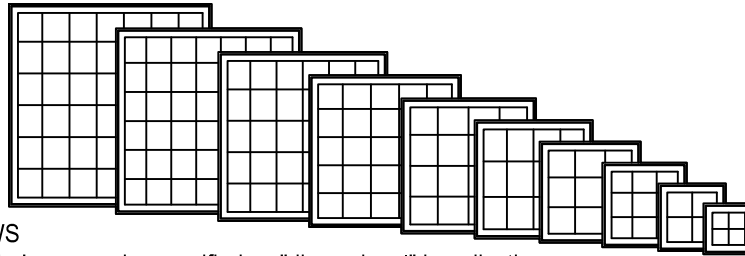

TABLE OF CONTENTS

Table of Contents.	3-1
General Information.	3-2
Grille & SDL Patterns.	3-3
Casement Handling & Operation.	3-4
Unit Sizing, Rough Opening & Masonry Openings	3-5
Trim Options	3-6
Sector Top Trim Options	3-7
Jamb Options	3-8
Mullion Details & Specialty Trim	3-10
Casement Elevation Notes	3-15
General Sector Top Information	3-16
Sector Top Casement Handling & Operation	3-17
Sector Top Casement Elevation Notes	3-19
General Picture Casement Information	3-20
Picture Casement Elevation Notes	3-21
Section Details: 6" Scale.	3-22
Bays & Bows Opening Specifications	3-28
Min-Max Sizing Pages	3-31

GENERAL INFORMATION
CASEMENT



DIMENSIONAL WINDOWS

Custom clad casement windows may be specified as "dimensional" by adjusting the desired rough opening width or height in 1/16" increments from standard.

Custom clad casement windows are available with left or right hand operation, or stationary (non-venting). Operating mechanism includes corrosion resistant steel hinges and dual arm roto-type operator with hardened steel gears and operating arms. Sash locks are concealed unison type with an exposed locking lever and escutcheon plate. There are several interior hardware finish options. Refer to the Specifications for finish options.

MULTIPLE ASSEMBLIES

Custom clad casement windows may be mullered above, below, or beside other clad casement windows, or other clad window products. Factory assembled mulls are limited in height (100"), width (150").

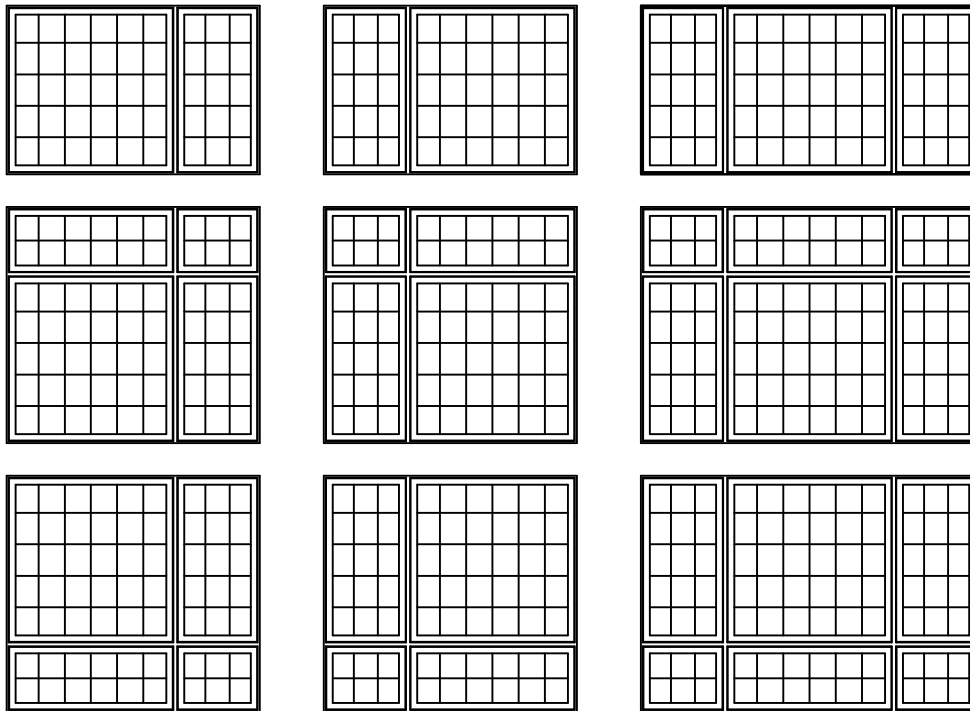

LITE CUT INFORMATION
CASEMENT & STATIONARY

Custom clad casement windows are available with removable grilles in 7/8", 1-1/8" and 1-3/8" widths, grids between the glass and Simulated Divided Lites. Standard lite cuts are rectangular, and conform to the layouts noted in the charts on the next page. To use the chart, refer to the appropriate table by the type of window and type of bars or grilles the section drawings illustrate. Then simply cross reference the frame Height and Width to determine the standard lite cut.

LITE CUT OPTIONS

Special lite cut patterns can include a wide variety of straight line and radius patterns. The illustrations shown here represent just a few of the possibilities. Rectangular, horizontal, vertical and Prairie lite patterns are available in all standard size clad casement windows. Uneven, diamond, radius and Gothic lite cuts are available, subject to approval. Approvals are based on the ability to fulfill the design requirement while maintaining the construction integrity of the finished product.

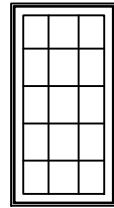

RECTANGULAR

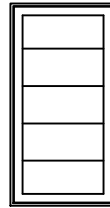

HORIZONTAL



PRAIRIE

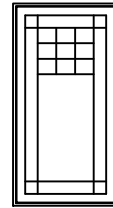

UNEVEN

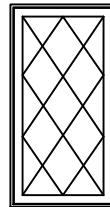

DIAMOND

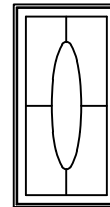

RADIUS

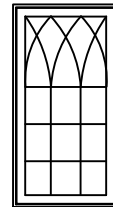

GOthic

BAR ALIGNMENT

Alignment of divided lite muntin bars from one window to the next is often required by fine architectural design. Wood grilles, Grids Between the Glass and Simulated Divided Lites may be specified with muntin bars aligned.

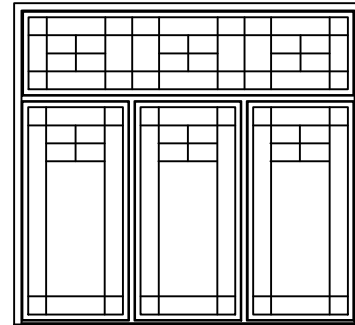

HANDING & OPERATION
CASEMENT

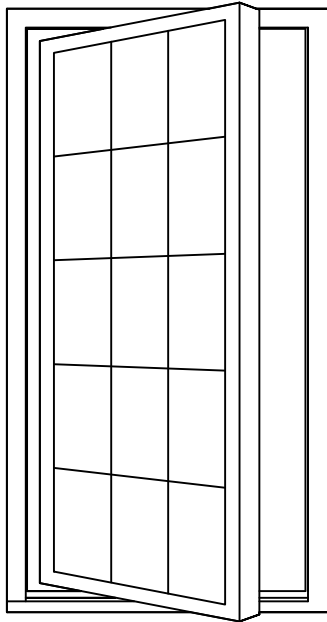

LEFT
HAND

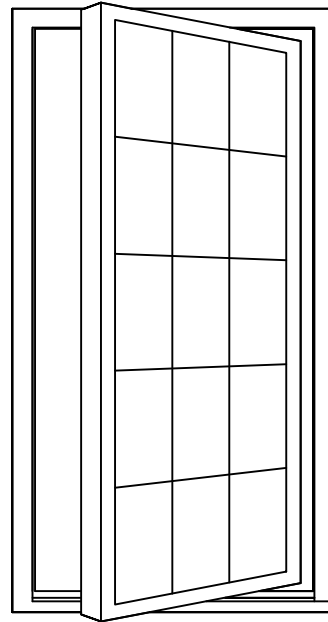

RIGHT
HAND

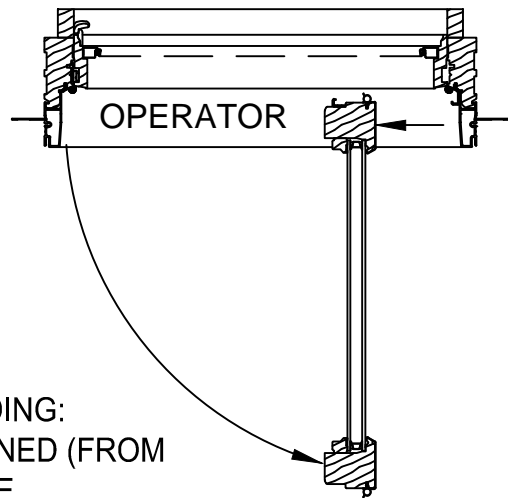
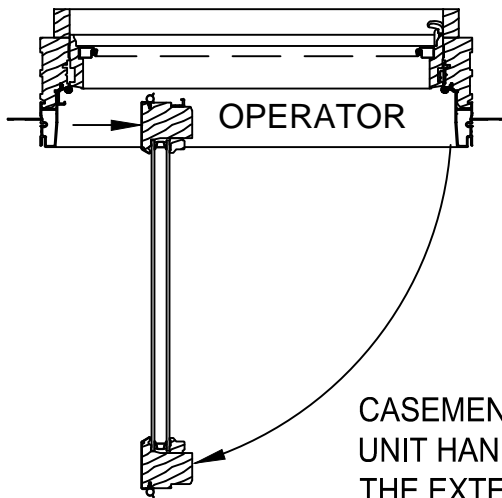

CASEMENT UNIT HANDING:
UNIT HANDING IS DEFINED (FROM
THE EXTERIOR) AS THE
DIRECTION THE SASH OPENS.

UNIT SIZING, ROUGH OPENINGS &
MASONRY OPENINGS
CASEMENT

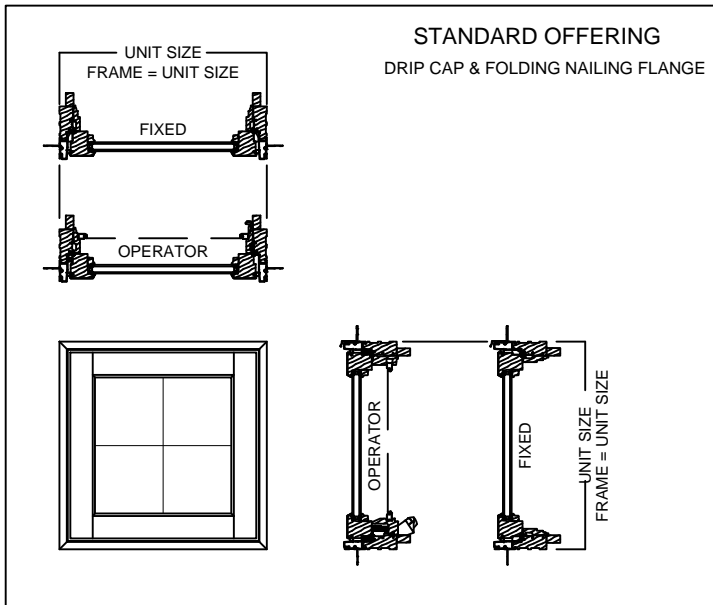

GENERAL NOTES:

UNITS WITH NO TRIM AND SILL NOSE:
UNIT SIZE = FRAME SIZE

UNIT SIZE IS ALWAYS THE
EXTREME SIZE OF THE WINDOW
WITH OR WITHOUT TRIM
(DRIP CAP & NAILING FLANGE ARE
NOT ADDED TO ANY UNIT SIZING)

MASONRY OPENING:

MASONRY OPENING IS ALWAYS 1/2" OVER
THE UNIT SIZE OF THE WINDOW

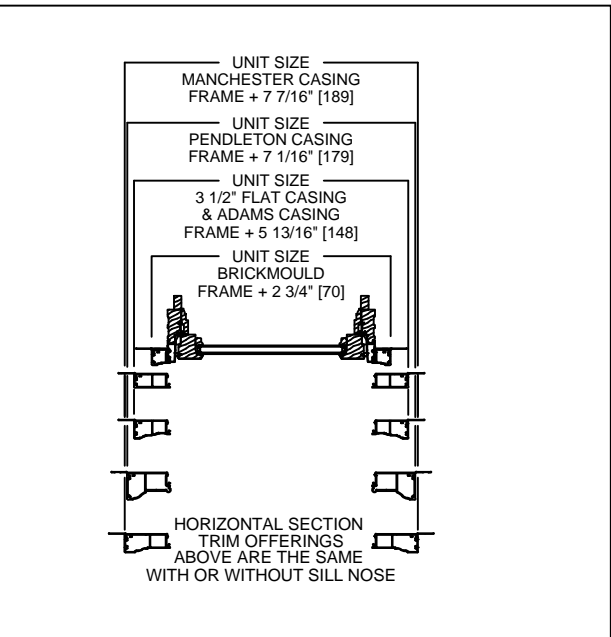
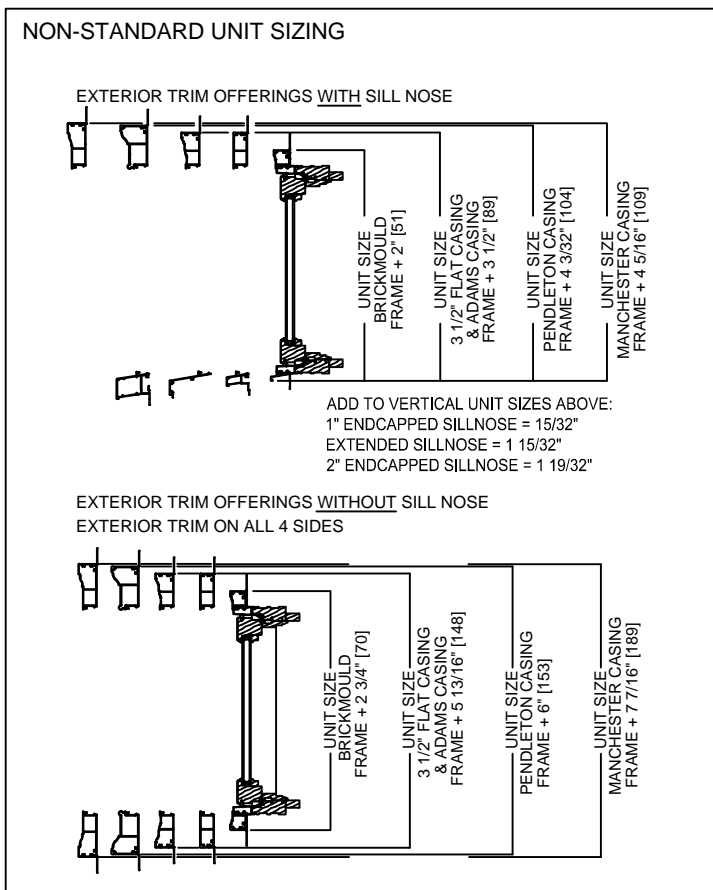
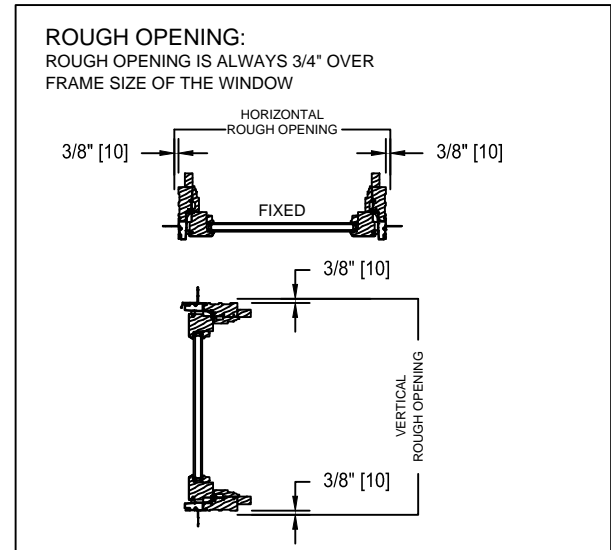

**TRIM OPTIONS
& SILL OPTIONS
CASEMENT**

EXTERIOR TRIM

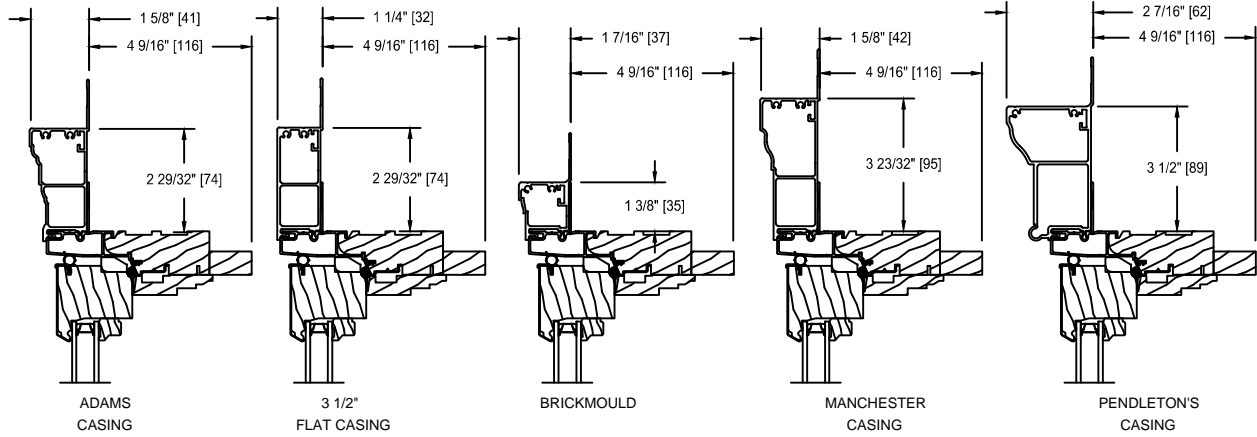

SILL NOSE OPTIONS

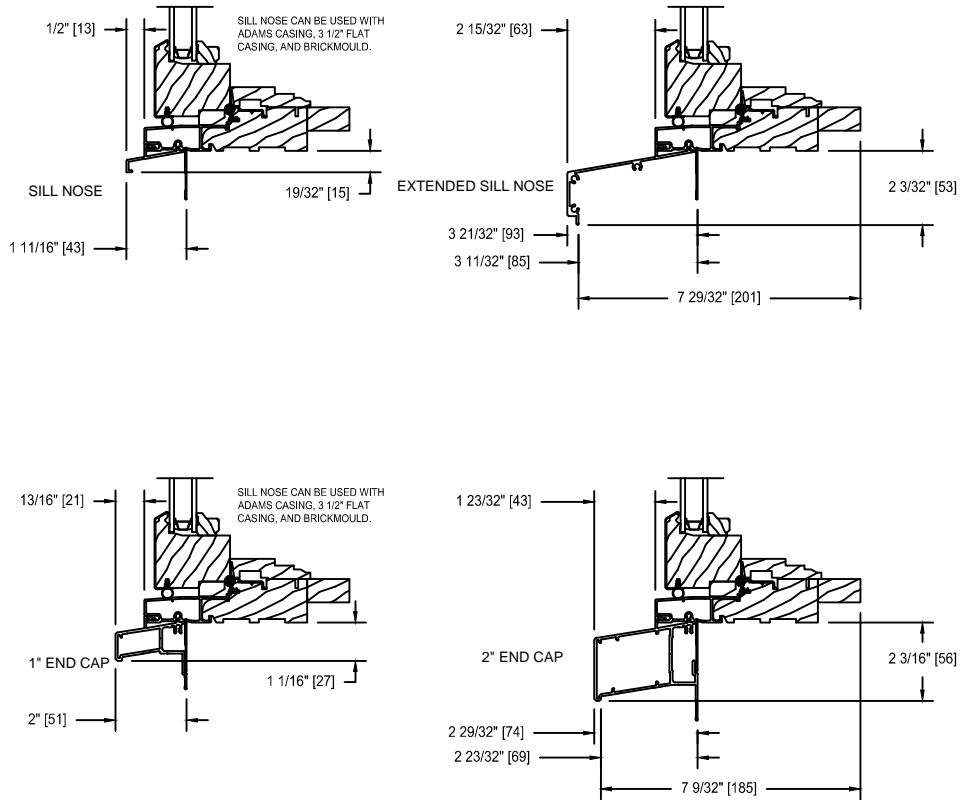

TRIM OPTIONS
SECTOR TOP

EXTERIOR TRIM

TRIM OPTIONS NOTE:
JAMB EXTENDERS & SILL OPTIONS ARE
CONSISTENT WITH CUSTOM CLAD CASEMENT
(STRAIGHTLINE).

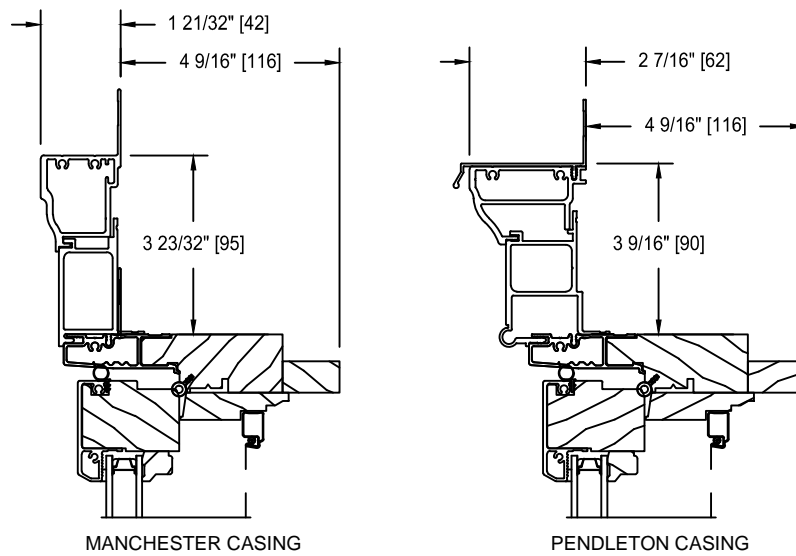
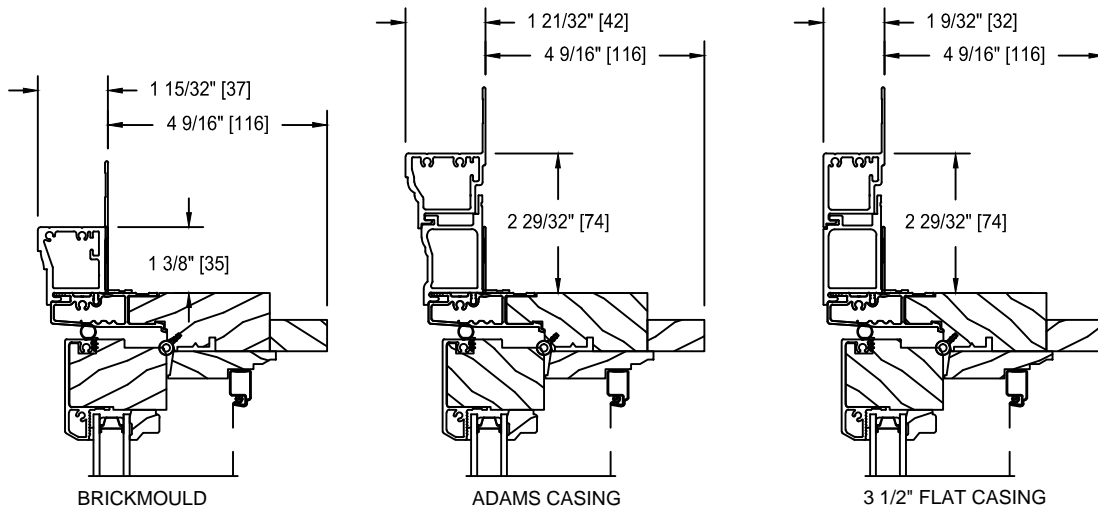

JAMB EXTENDER OPTIONS

4 9/16" WALL

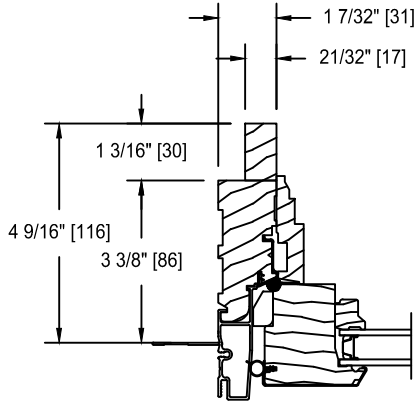

STANDARD 4/4
JAMB EXTENDER

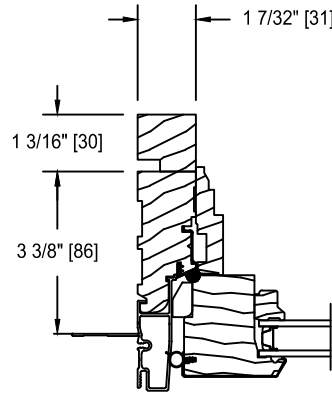

STANDARD 5/4
JAMB EXTENDER

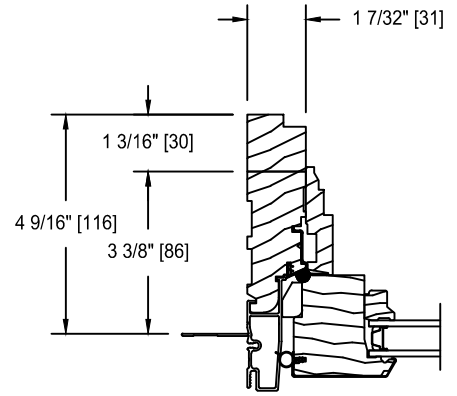

5/4 to 4/4 REVEAL
JAMB EXTENDER

6 9/16" WALL

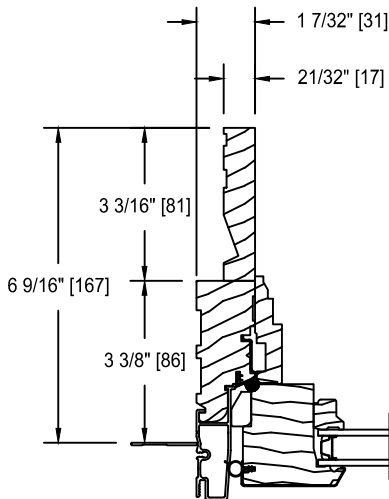

STANDARD 4/4
JAMB EXTENDER

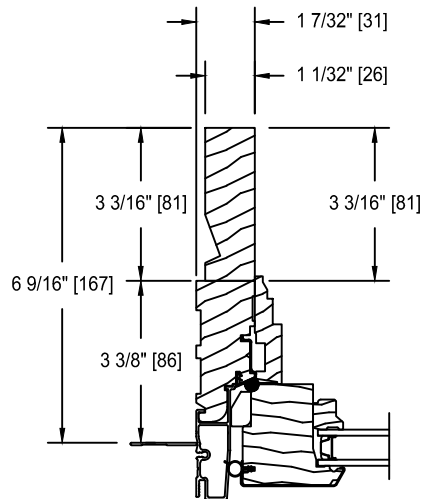

STANDARD 5/4
JAMB EXTENDER

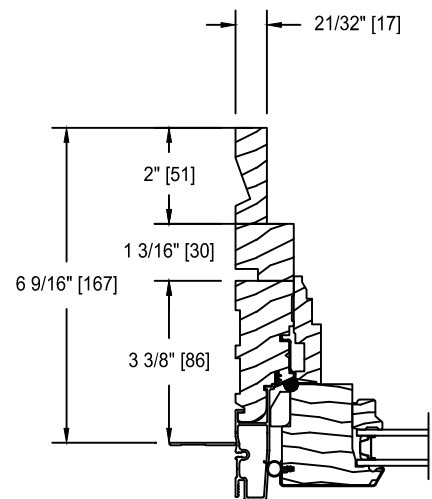

5/4 to 4/4 REVEAL
JAMB EXTENDER

MAXIMUM JAMB WIDTHS

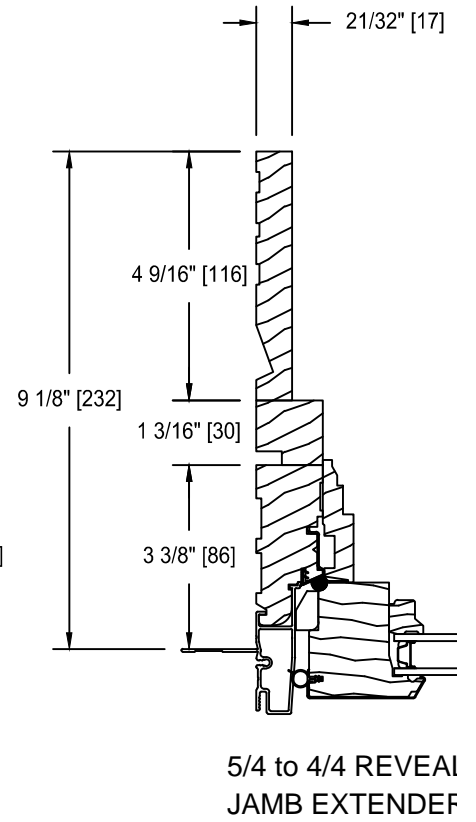
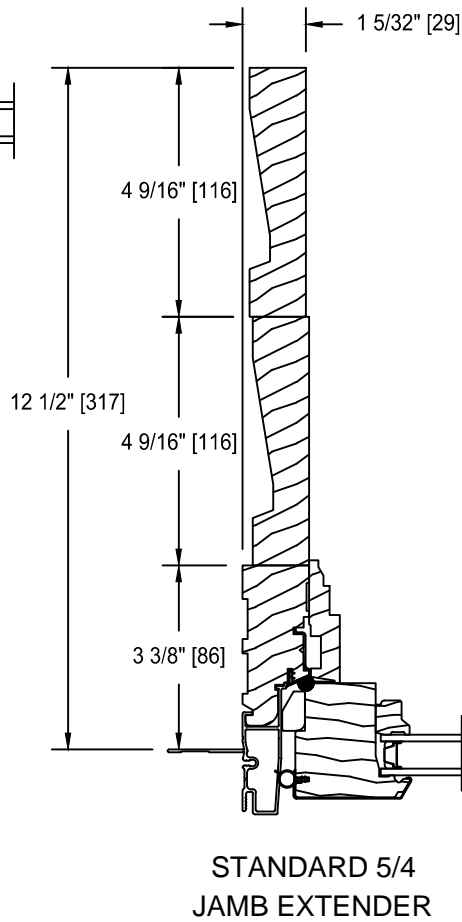
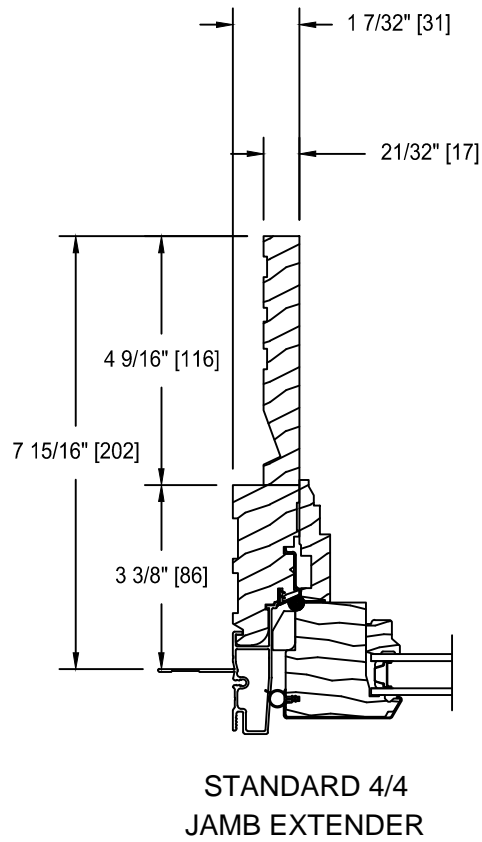

STANDARD MULLION DETAILS

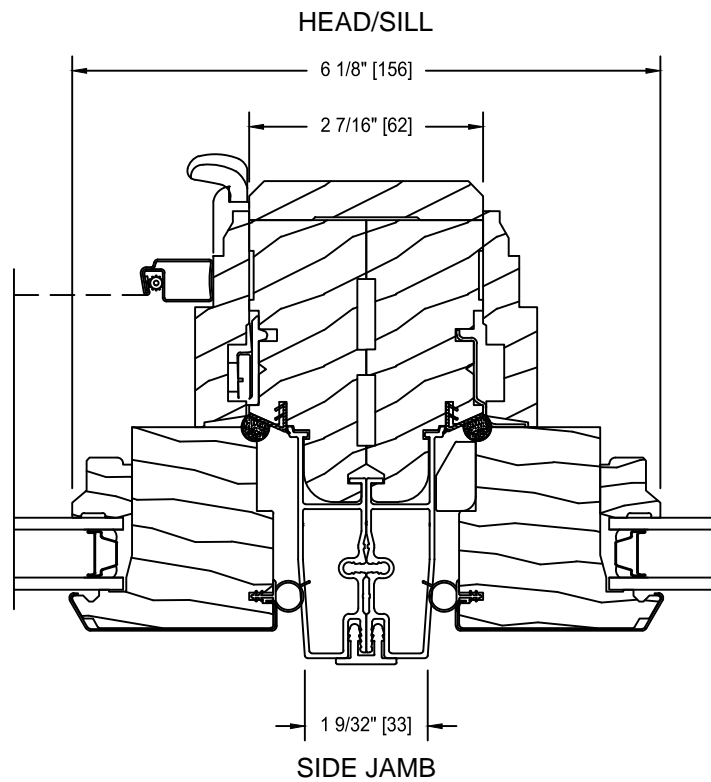
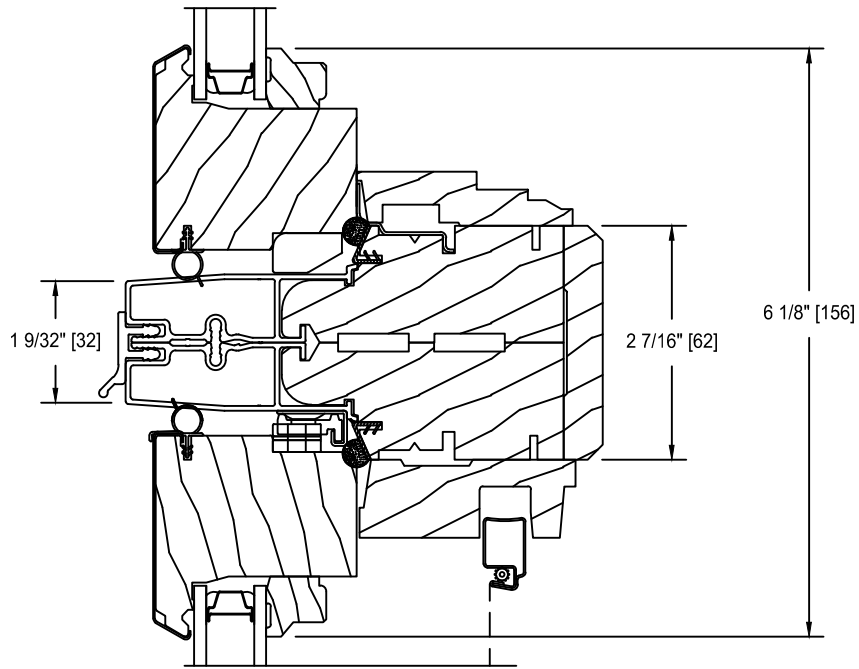

FRAME EXTENSIONS & RETURNS

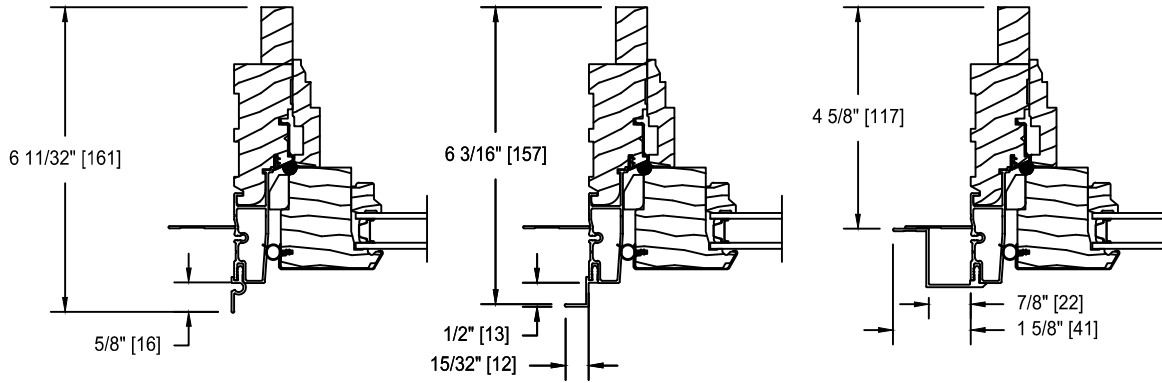

FRAME EXPANDERS
STRAIGHTLINE ONLY

FRAME EXPANDER CAPS
STRAIGHTLINE ONLY

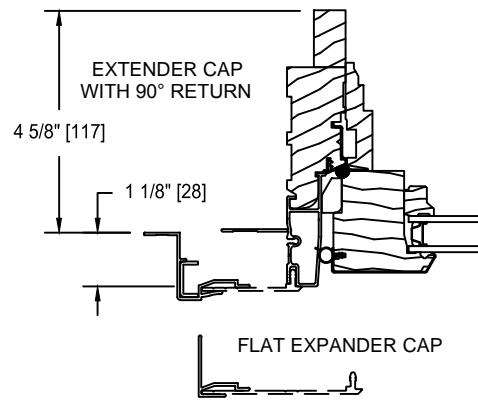
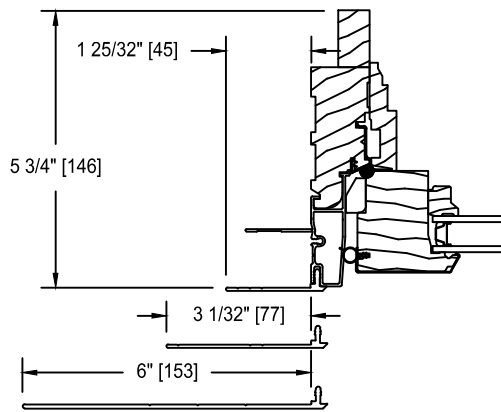

SNAP TRIM OPTIONS

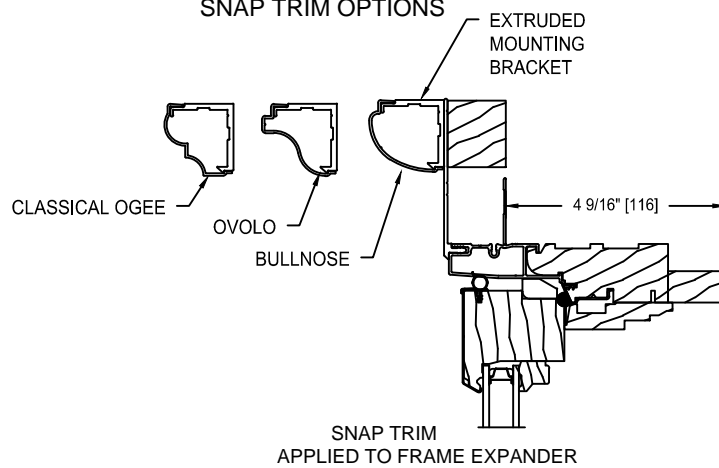

SPECIALTY TRIM & MULLION DETAILS
SPREAD MULLION DETAILS

EXTERIOR SPREAD MULLIONS &
STUD POCKET COVERS

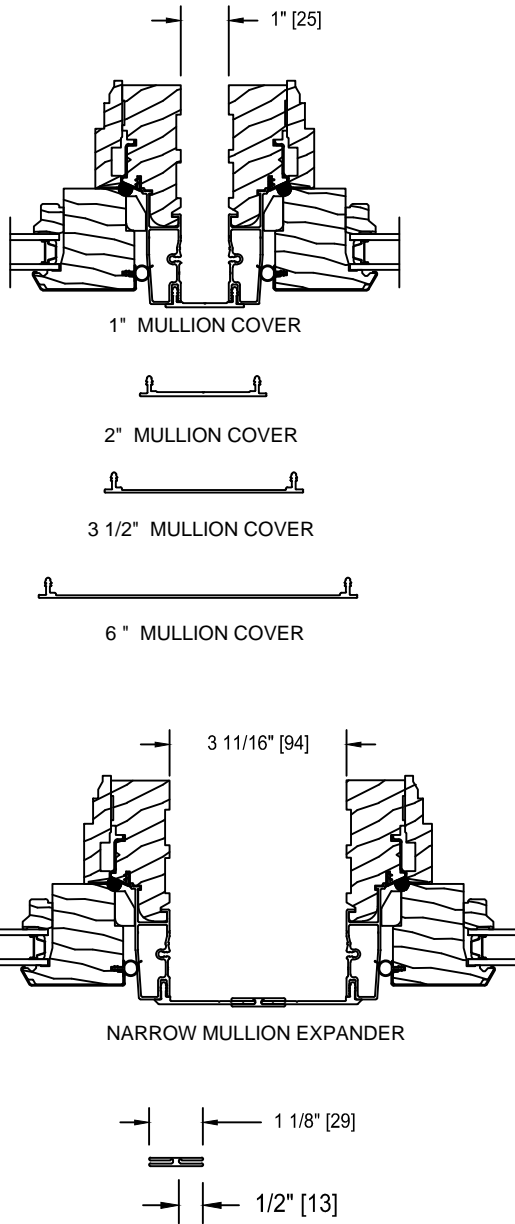

90° CORNER MULLION

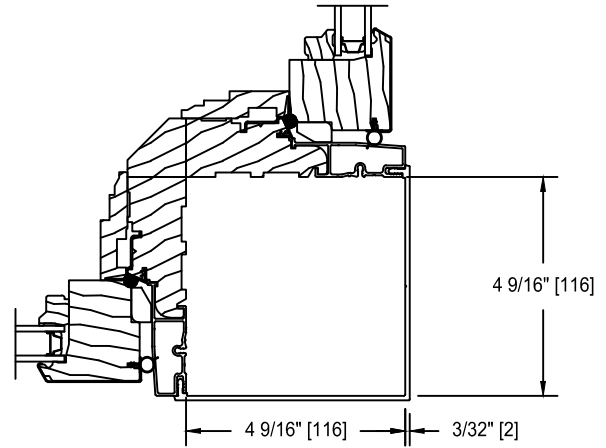

MULLION EXPANDERS

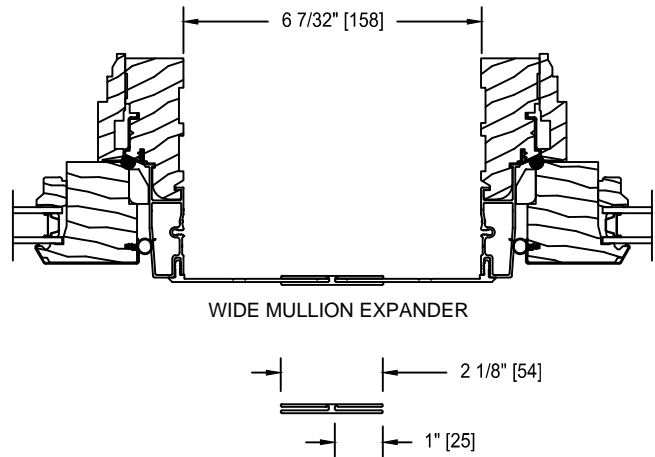

SPECIALTY TRIM & MULLION DETAILS
SPREAD MULLION DETAILS

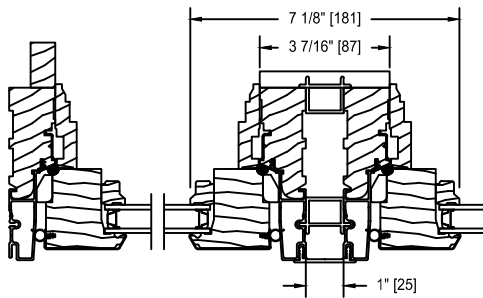
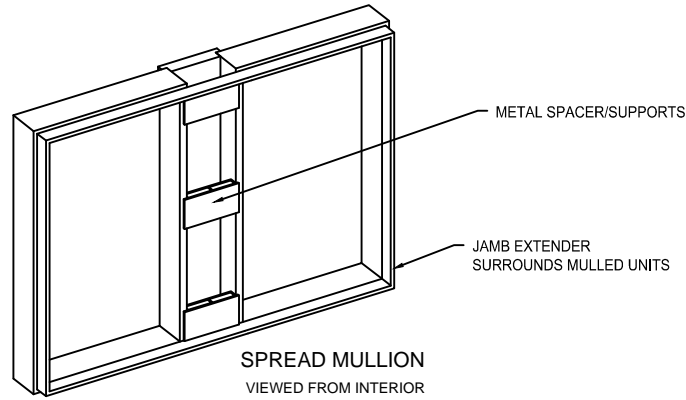

1" SPREAD MULLION

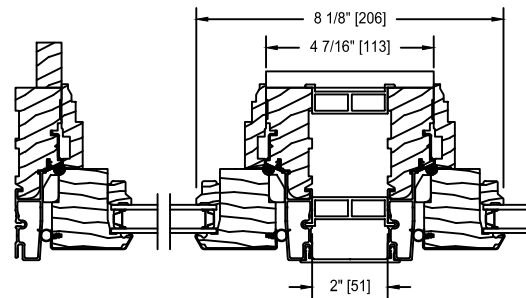

2" SPREAD MULLION

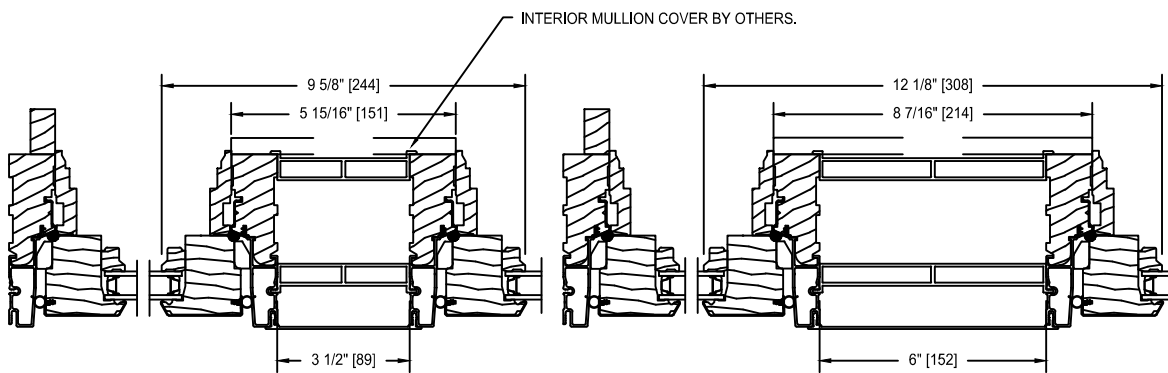

3 1/2" SPREAD MULLION

6" SPREAD MULLION

SPECIALTY TRIM & MULLION DETAILS
STUD POCKET DETAILS

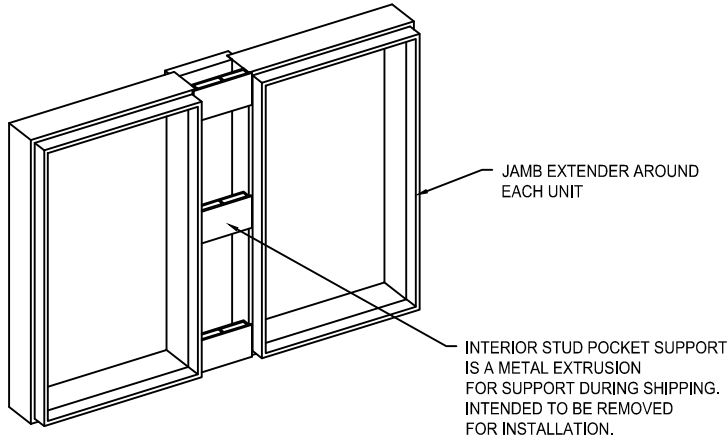

STUD POCKET MULLION
VIEWED FROM INTERIOR

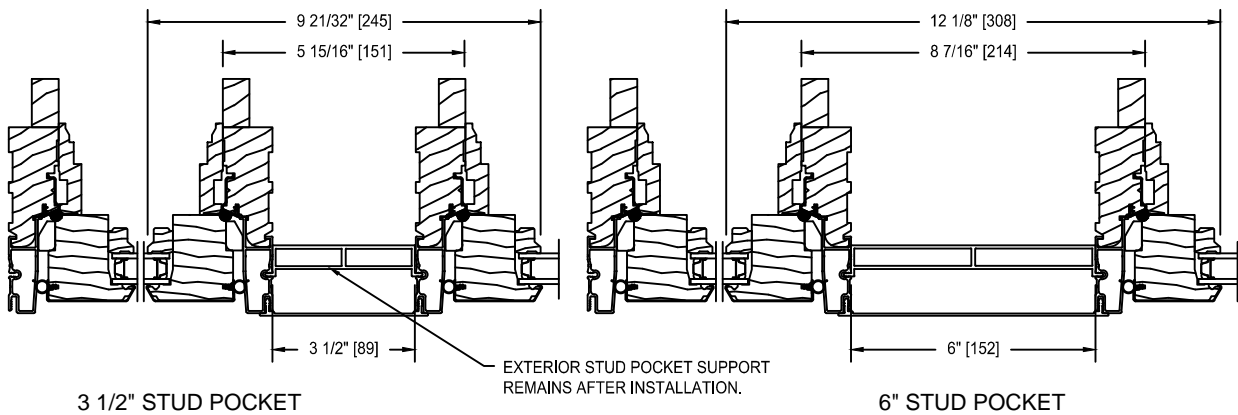
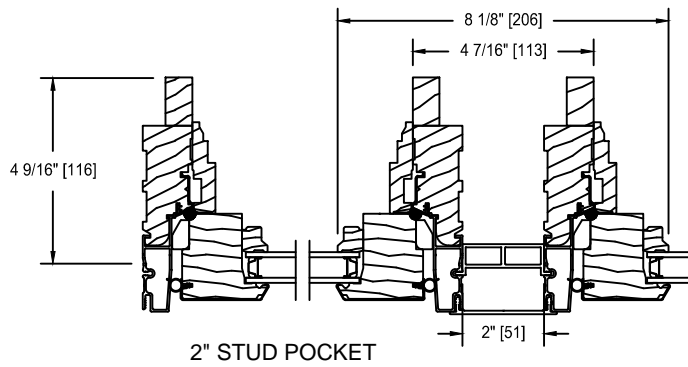

ELEVATION NOTES
CASEMENT

ELEVATION DRAWINGS UTILIZE A LIMITED NUMBER OF PROJECTED LINES TO PRODUCE A RUDIMENTARY DRAWING INTENDED TO BE USED IN A SMALL GRAPHICAL SCALE. ELEVATIONS ARE VIEWED PERPENDICULAR FROM THE EXTERIOR OF THE STRUCTURE. IF MORE DIMENSIONS ARE NEEDED, USE THE SECTION DRAWINGS FOR MORE COMPLETE DEPICTIONS.

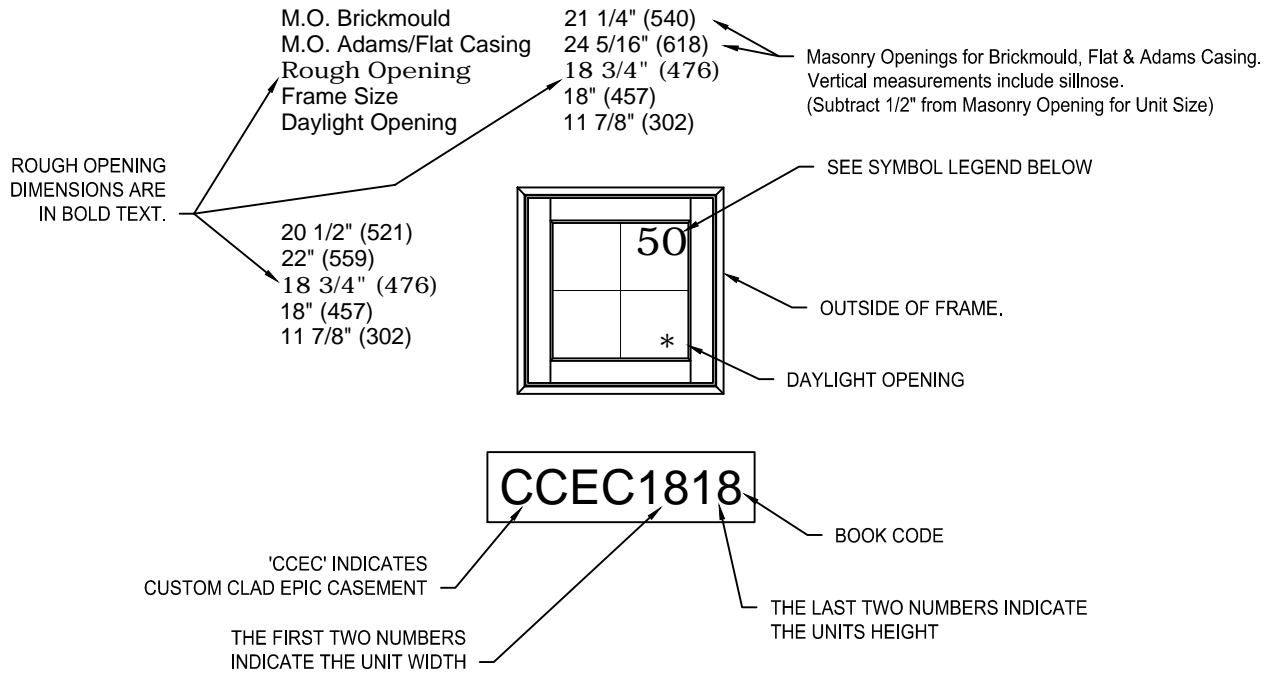

GENERAL CASEMENT NOTES

1. CUSTOM EPIC CLAD CASEMENT (CCEC) UNITS ARE AVAILABLE AS OPERATING OR FIXED UNITS.
2. 'CCEC' IN A BOOK CODE DENOTES THE UNIT IS A CUSTOM CLAD EPIC CASEMENT UNIT.
3. UNIT ELEVATIONS ARE SHOWN WITHOUT EXTERIOR TRIM. UNIT SIZES & MASONRY OPENING DIMENSIONS WILL CHANGE WITH THE ADDITION OF EXTERIOR TRIM. SEE THE 'UNIT SIZING, ROUGH OPENINGS & MASONRY OPENINGS' PAGE FOR EXTERIOR TRIM EFFECTS.
4. OPERATING UNITS ARE AVAILABLE AS LEFT OR RIGHT HAND OPERATION.
5. DIMENSIONAL VALUES IN BRACKETS ARE MILLIMETER CONVERSIONS.

ELEVATION SYMBOL LEGEND:

- E** BASIC UNIT CLEAR OPENING EXCEEDS 20" IN WIDTH, 24" IN HEIGHT & A MINIMUM OF 5.7 SQ. FT.
- E*** BASIC UNIT CLEAR OPENING REQUIRES EGRESS HINGES TO EXCEED 20" IN WIDTH, 24" IN HEIGHT & A MINIMUM OF 5.7 SQ. FT.
- E1** BASIC UNIT CLEAR OPENING EXCEEDS 20" IN WIDTH, 24" IN HEIGHT & A MINIMUM OF 5.0 SQ. FT.
- S** STATIONARY UNIT.
- ##** NUMBER INDICATES PERFORMANCE GRADE (PG) RATING WITH STANDARD GLAZING. OPERATING UNITS UTILIZE THE R65 LOCKING SYSTEM FOR DP RATINGS.

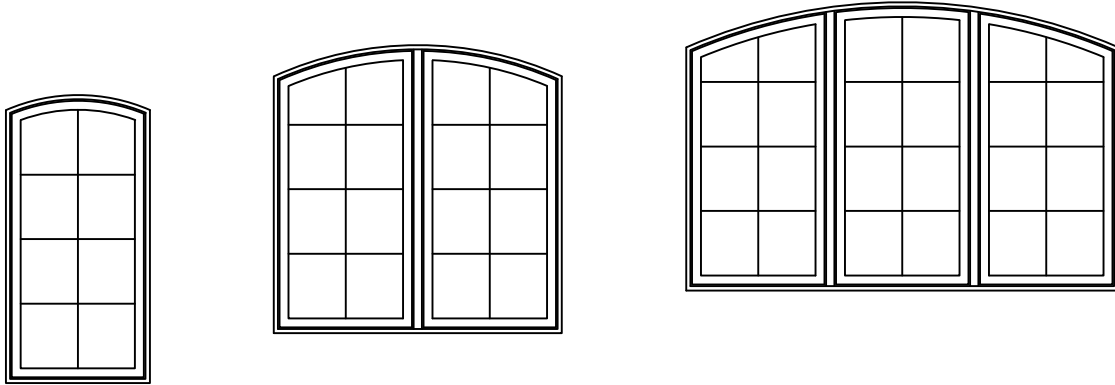
GENERAL INFORMATION
SECTOR TOP

Custom sector clad casements are constructed the same as EPIC clad casements with roll formed cladding on wood sash.

Custom sector clad casement windows are available with left or right hand operation (hinged on the springline), or stationary (non-venting). Operating mechanism includes stainless steel, corrosion resistant, butt hinges and single arm roto-type operator with hardened steel gears and operating arm. Sash locks are concealed unison type with an exposed locking lever and escutcheon plate. There are several interior hardware finish options. Refer to the Specifications for finish options.

CUSTOM EPIC CLAD CASEMENT SECTOR TOPS utilize some of the same options as CUSTOM EPIC CLAD CASEMENTS. Those options have not been repeated here in this sub-section.

HANDING & OPERATION
SECTOR TOP

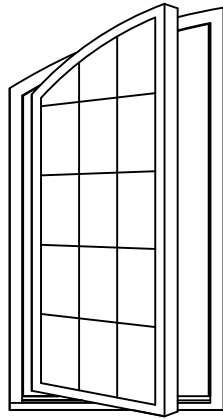

LEFT
HAND

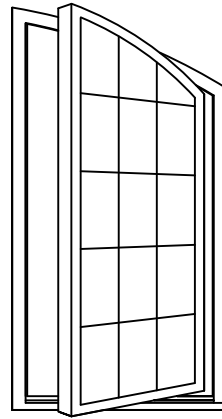

RIGHT
HAND

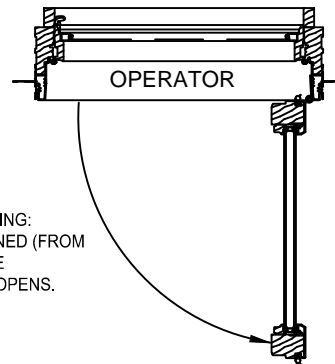
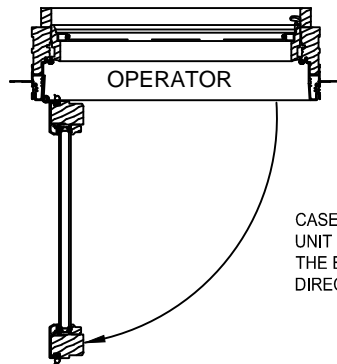

CASEMENT UNIT HANDING:
UNIT HANDING IS DEFINED (FROM
THE EXTERIOR) AS THE
DIRECTION THE SASH OPENS.

UNIT HANDING INFORMATION

OPERATING SINGLE SECTOR UNITS - MAY BE HANDED 'LEFT' OR 'RIGHT'.

OPERATING TWIN SECTOR UNITS - THESE UNITS ARE HINGED ON THE SPRINGLINE SIDE. THE 'LEFT' SASH HAS 'LEFT' HAND OPERATION AND THE 'RIGHT' SASH HAS 'RIGHT' HAND OPERATION ONLY.

OPERATING TRIPLE SECTOR UNITS - ONLY THE FLANKING UNITS MAY BE OPERATORS WHICH ARE HINGED ON THE SPRINGLINE SIDE. THE TWO OPERATING SASH ARE HANDED THE SAME AS THE TWIN SECTOR.

CLEAR OPENING INFORMATION
SECTOR TOP

CLEAR OPENINGS

THE CLEAR OPENINGS SHOWN ABOVE ILLUSTRATE THE VERTICAL CLEAR OPENING TO THE INTERIOR SPRINGLINE OF FRAME FEATURES.

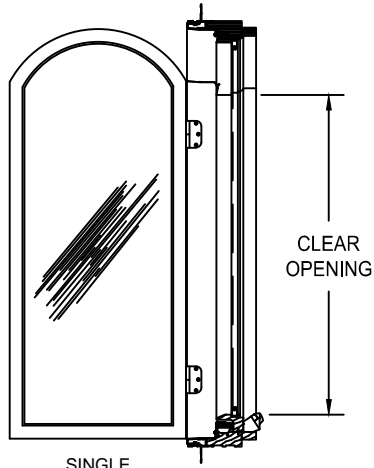

SINGLE
SECTOR

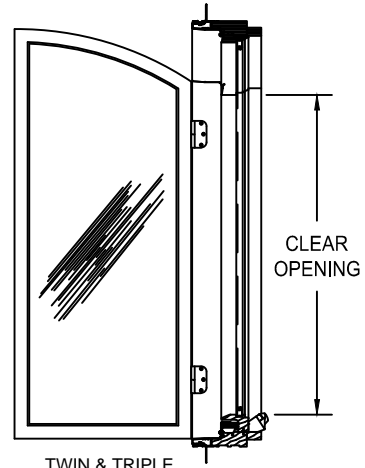

TWIN & TRIPLE
HANDED SECTOR

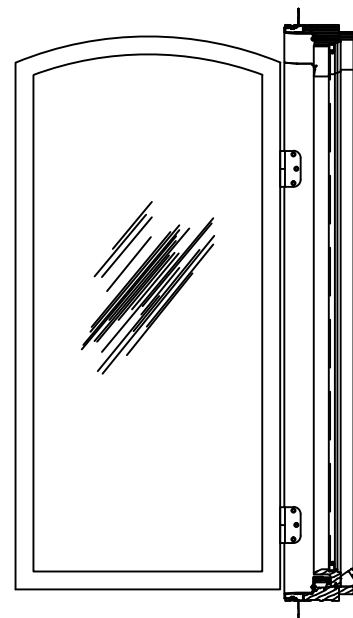
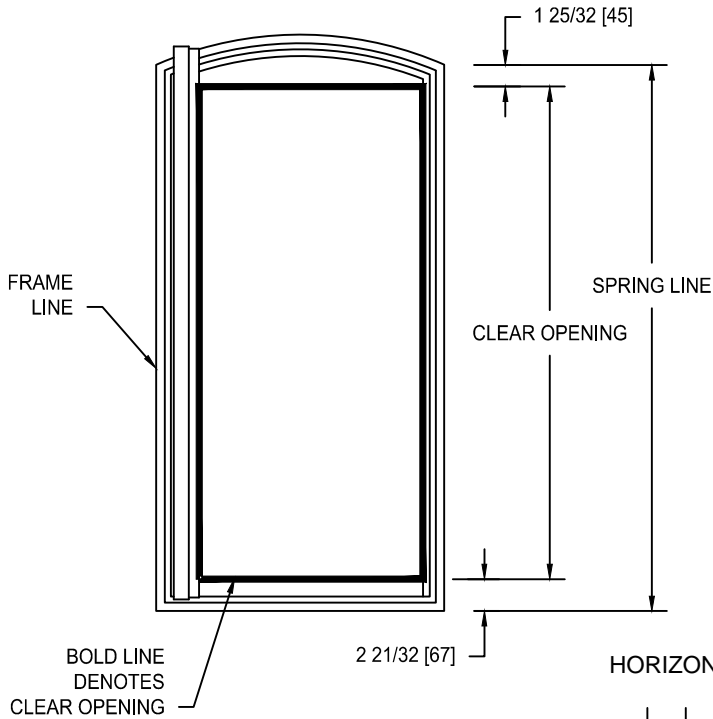

HORIZONTAL CLEAR OPENING

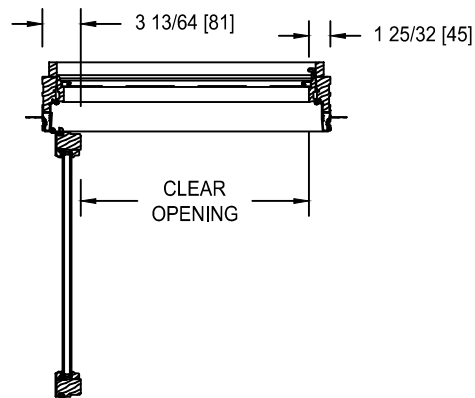

ELEVATION NOTES
SECTOR TOP

ELEVATION DRAWINGS UTILIZE A LIMITED NUMBER OF PROJECTED LINES TO PRODUCE A RUDIMENTARY DRAWING INTENDED TO BE USED IN A SMALL GRAPHICAL SCALE. ELEVATIONS ARE VIEWED PERPENDICULAR FROM THE EXTERIOR OF THE STRUCTURE. IF MORE DIMENSIONS ARE NEEDED, USE THE SECTION DRAWINGS FOR MORE COMPLETE DEPICTIONS.

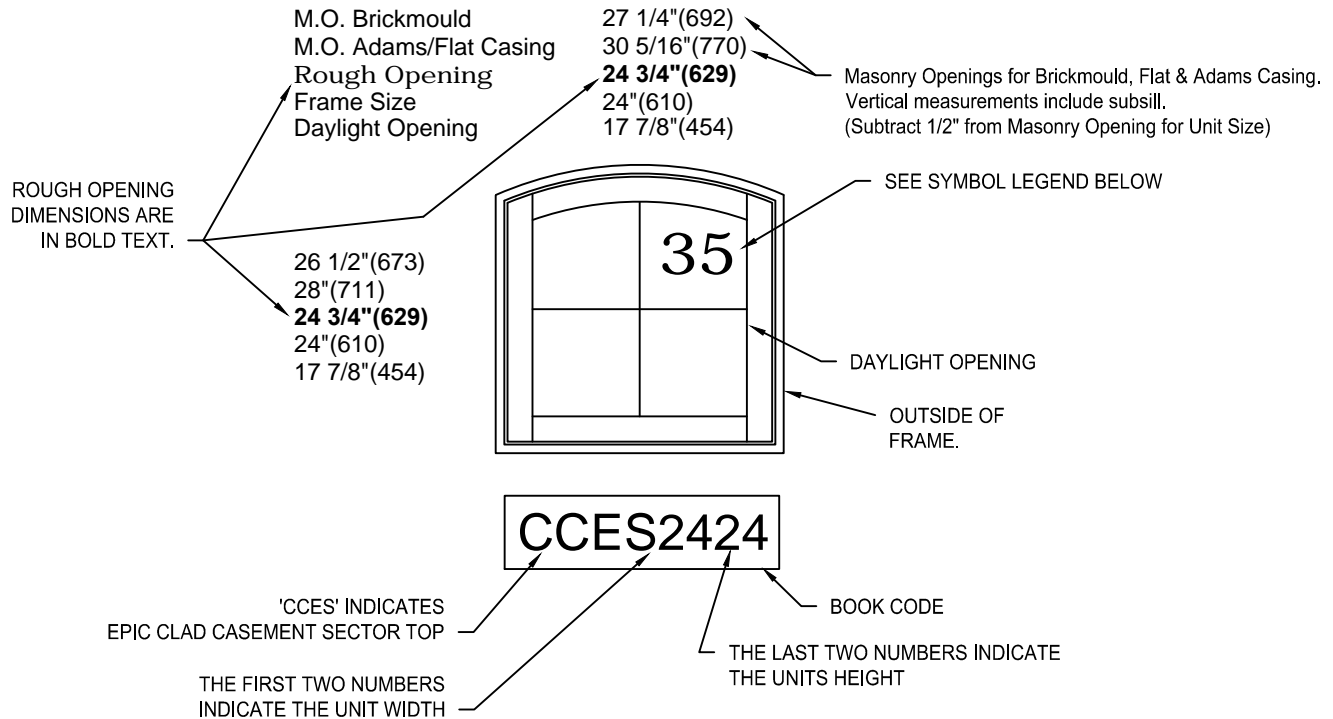

GENERAL RADIUS CASEMENT NOTES

1. 'CCES' IN A BOOK CODE DENOTES THE UNIT IS A CUSTOM CLAD EPIC CASEMENT SECTOR TOP UNIT.
2. UNIT ELEVATIONS ARE SHOWN WITH BRICKMOULD AND SUBSILL.
3. DIMENSIONAL VALUES IN BRACKETS ARE MILLIMETER CONVERSIONS.
4. ALL SECTOR UNITS ARE AVAILABLE AS OPERATING UNITS.
5. BOOKCODED SECTOR TOP UNITS HAVE ROLL FORM SASH.

ELEVATION SYMBOL LEGEND:

- E** BASIC UNIT CLEAR OPENING EXCEEDS 20" IN WIDTH, 24" IN HEIGHT & A MINIMUM OF 5.7 SQ. FT.
- E*** BASIC UNIT CLEAR OPENING REQUIRES EGRESS HINGES TO EXCEED 20" IN WIDTH, 24" IN HEIGHT & A MINIMUM OF 5.7 SQ. FT.
- E1** BASIC UNIT CLEAR OPENING EXCEEDS 20" IN WIDTH, 24" IN HEIGHT & A MINIMUM OF 5.0 SQ. FT.
- S** STATIONARY UNIT
- ##** NUMBER INDICATES PERFORMANCE GRADE (PG) RATING WITH STANDARD GLAZING. OPERATING UNITS UTILIZE THE R65 LOCKING SYSTEM FOR DP RATINGS.

GENERAL INFORMATION STATIONARY CASEMENT

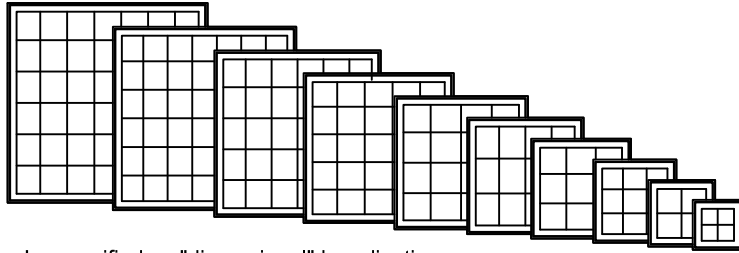

DIMENSIONAL WINDOWS

Custom clad casement windows may be specified as "dimensional" by adjusting the desired rough opening width or height in 1/16" increments from standard.

Custom clad casement windows are available with left or right hand operation, or stationary (non-venting). Operating mechanism includes corrosion resistant steel hinges and dual arm roto-type operator with hardened steel gears and operating arms. Sash locks are concealed unison type with an exposed locking lever and escutcheon plate. There are several interior hardware finish options. Refer to the Specifications for finish options.

MULTIPLE ASSEMBLIES

Custom clad casement windows may be mullied above, below, or beside other clad casement windows, or other clad window products. Factory assembled mulls are limited in height (100"), width (150").

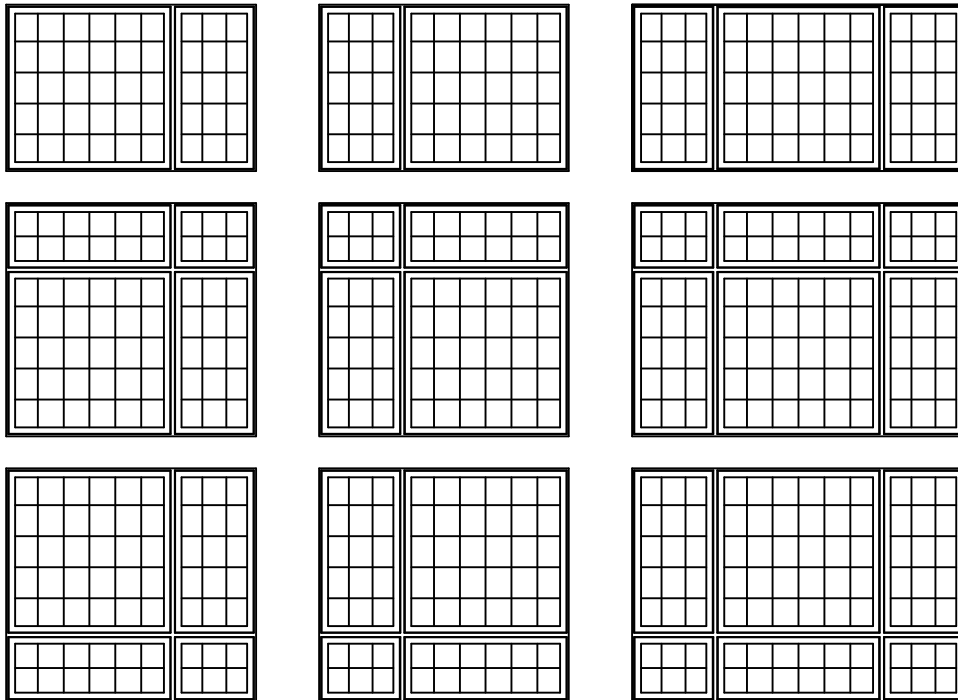

ELEVATION NOTES
STATIONARY CASEMENT

ELEVATION DRAWINGS UTILIZE A LIMITED NUMBER OF PROJECTED LINES TO PRODUCE A RUDIMENTARY DRAWING INTENDED TO BE USED IN A SMALL GRAPHICAL SCALE. ELEVATIONS ARE VIEWED PERPENDICULAR FROM THE EXTERIOR OF THE STRUCTURE. IF MORE DIMENSIONS ARE NEEDED, USE THE SECTION DRAWINGS FOR MORE COMPLETE DEPICTIONS.

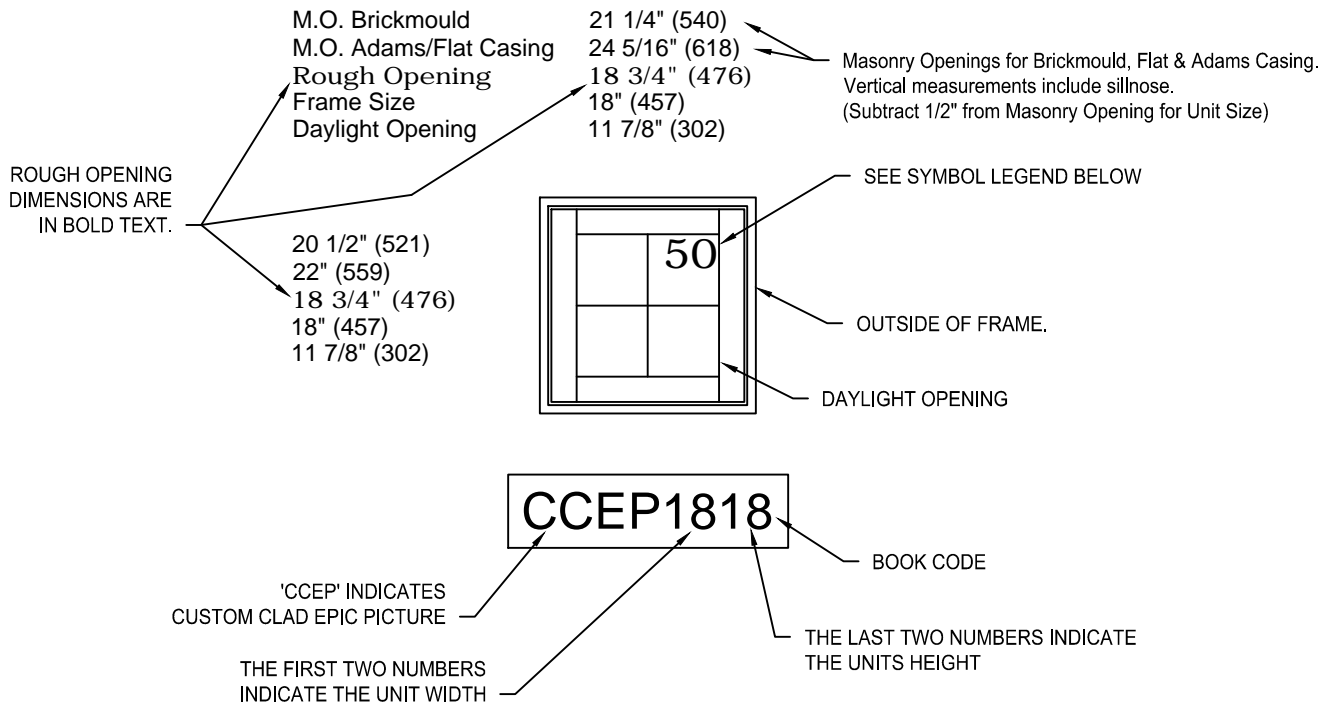

GENERAL CASEMENT NOTES

1. (CCEP) IN A BOOK CODE DENOTES THAT THE UNIT IS A CUSTOM CLAD EPIC PICTURE (FIXED) CASEMENT UNIT.
2. UNIT ELEVATIONS ARE SHOWN WITH BRICKMOULD AND SUBSILL.
3. ELEVATION DRAWINGS SHOW STANDARD LIGHT CUTS FOR 7/8" [22] OR 1 1/8" [29] GRILLE BARS OR SIMULATED DIVIDED LITE.
4. DIMENSIONAL VALUES IN BRACKETS ARE MILLIMETER CONVERSIONS.
5. ALL GLASS SIZES ARE NOMINAL.

ELEVATION SYMBOL LEGEND:

NUMBER INDICATES PERFORMANCE GRADE (PG) RATING WITH STANDARD GLAZING. OPERATING UNITS UTILIZE A CONCEALED LOCKING SYSTEM FOR DP RATINGS.

OPERATING UNIT
VERTICAL SECTION

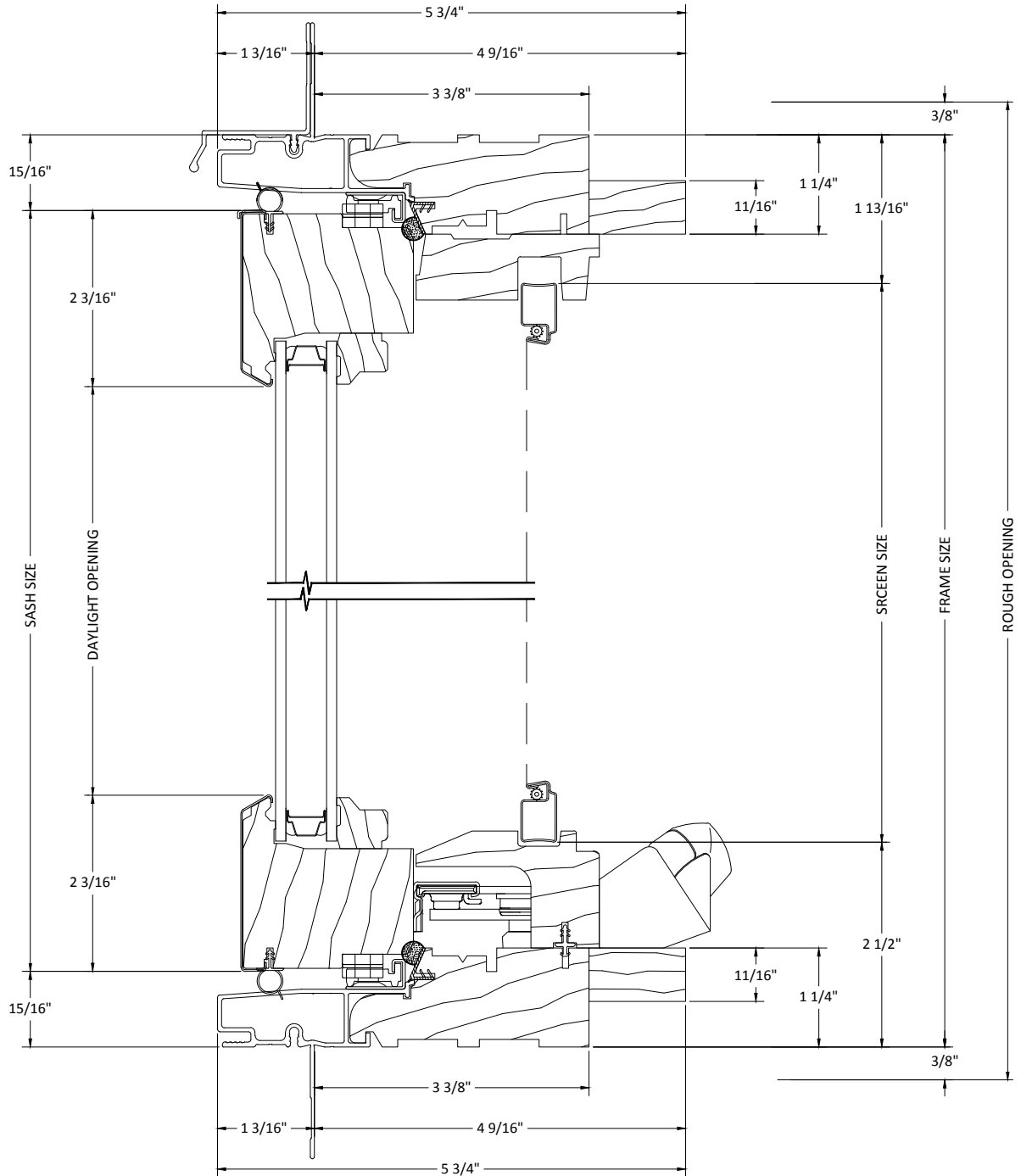

OPERATING UNIT
HORIZONTAL SECTION

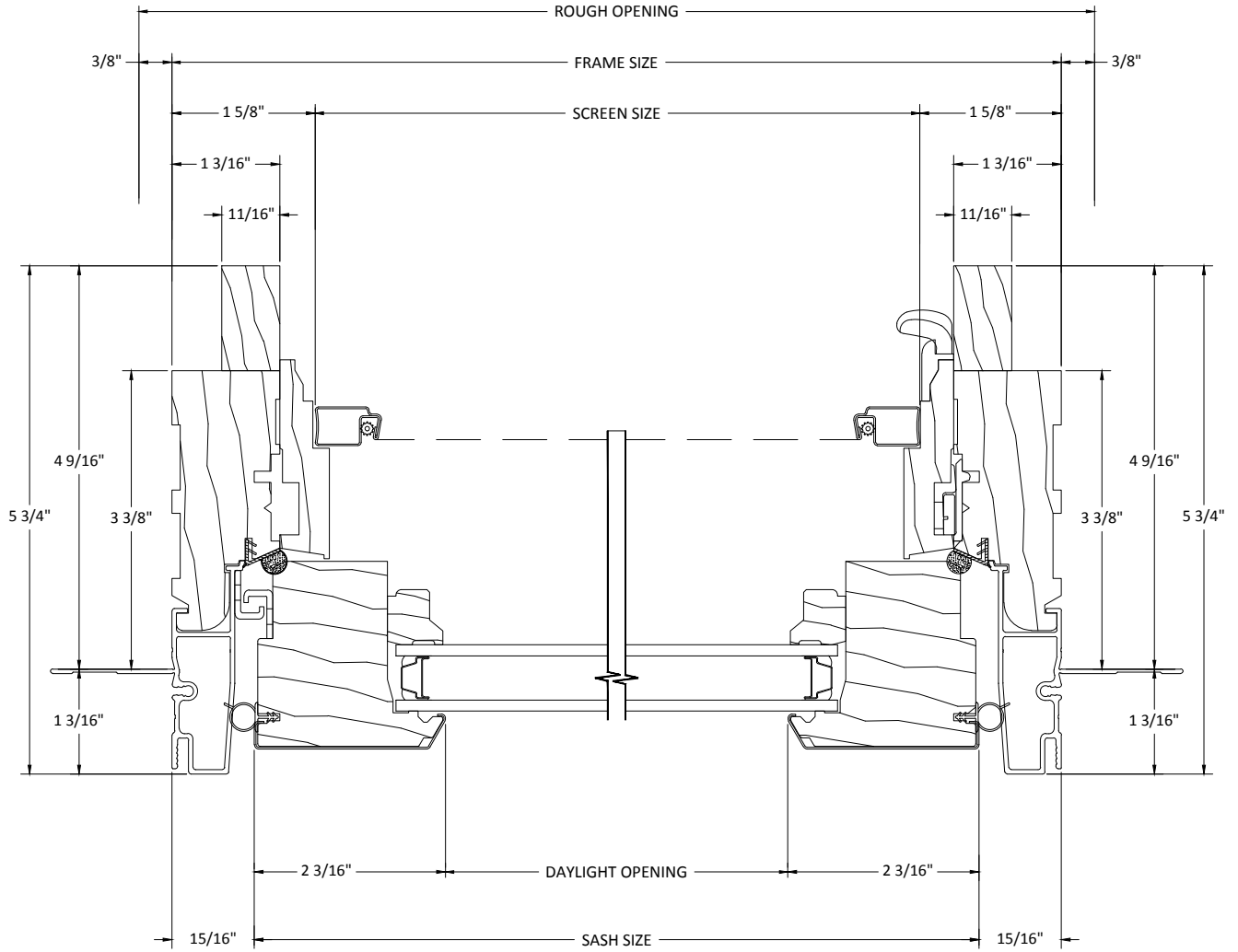

STATIONARY UNIT
VERTICAL SECTION

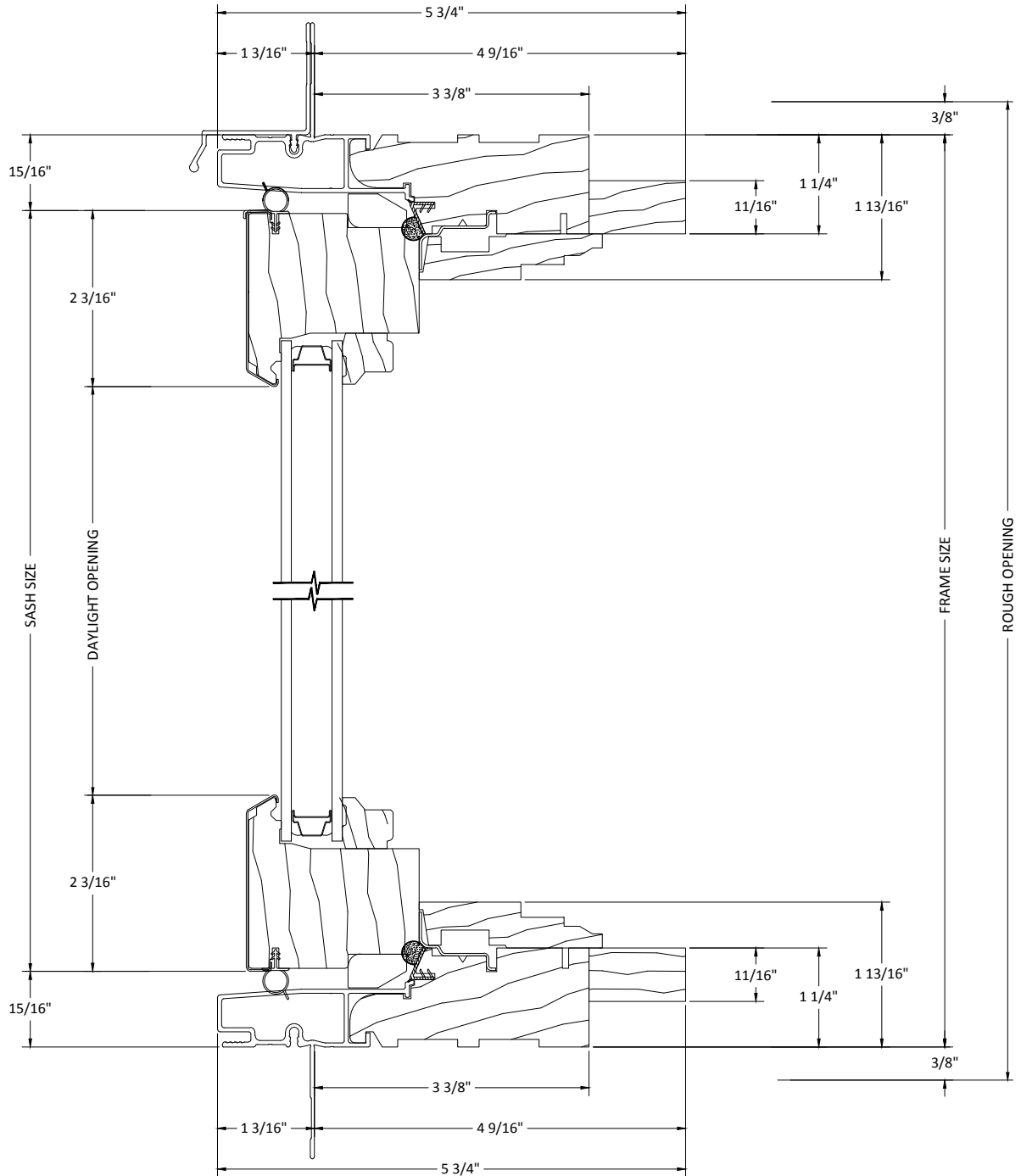

STATIONARY UNIT
HORIZONTAL SECTION

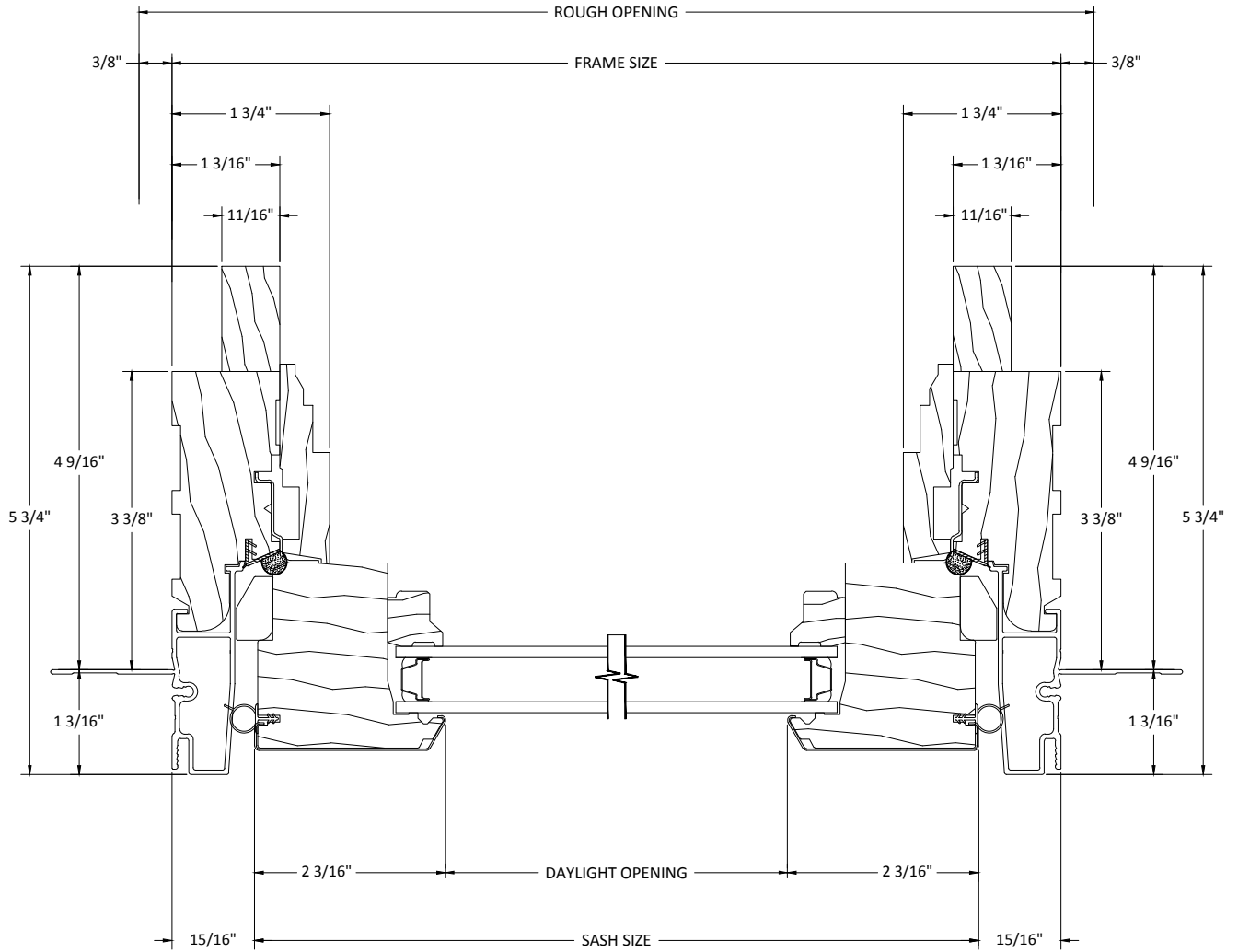

RADIUS UNIT
VERTICAL SECTION

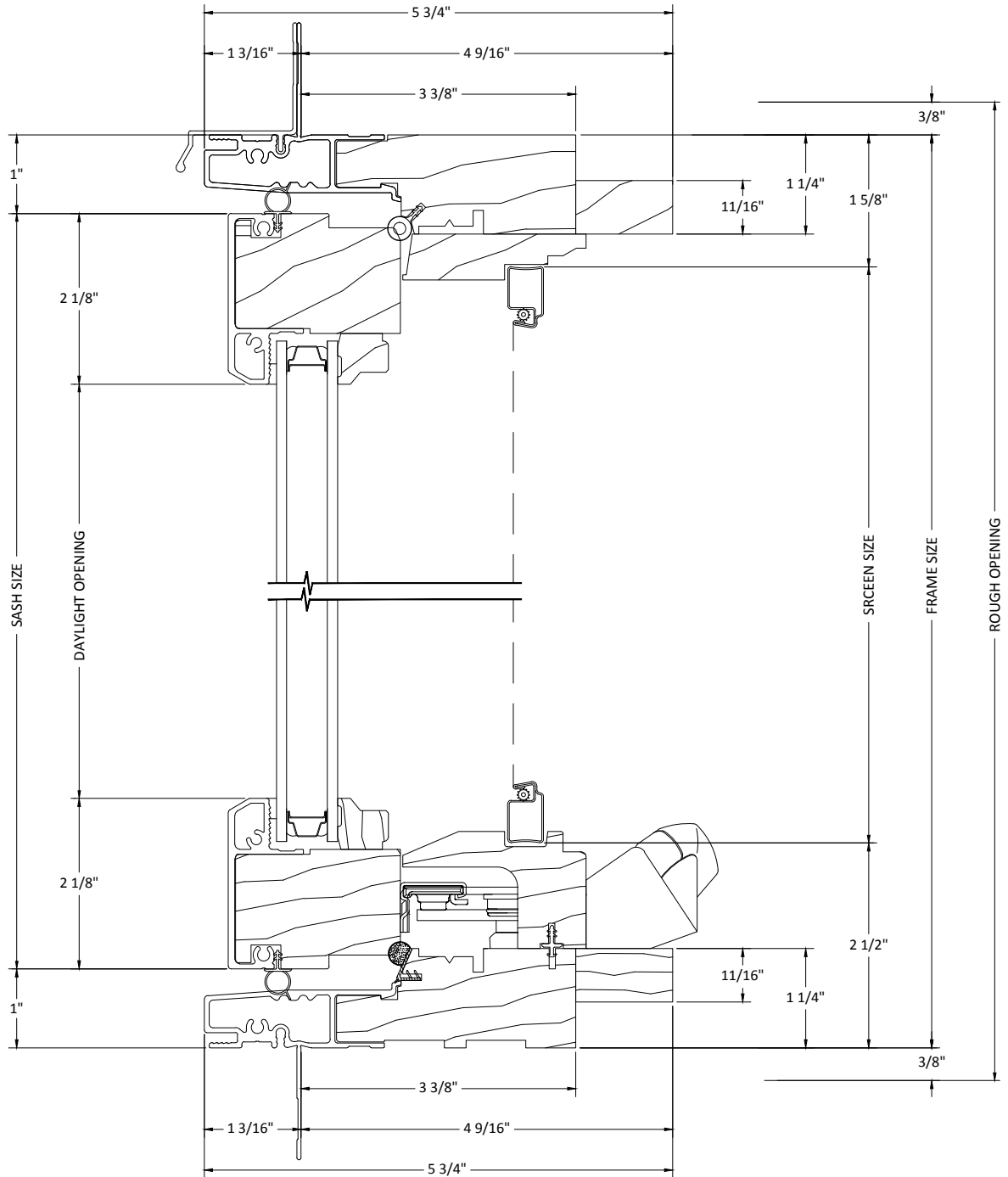

RADIUS UNIT
HORIZONTAL SECTION

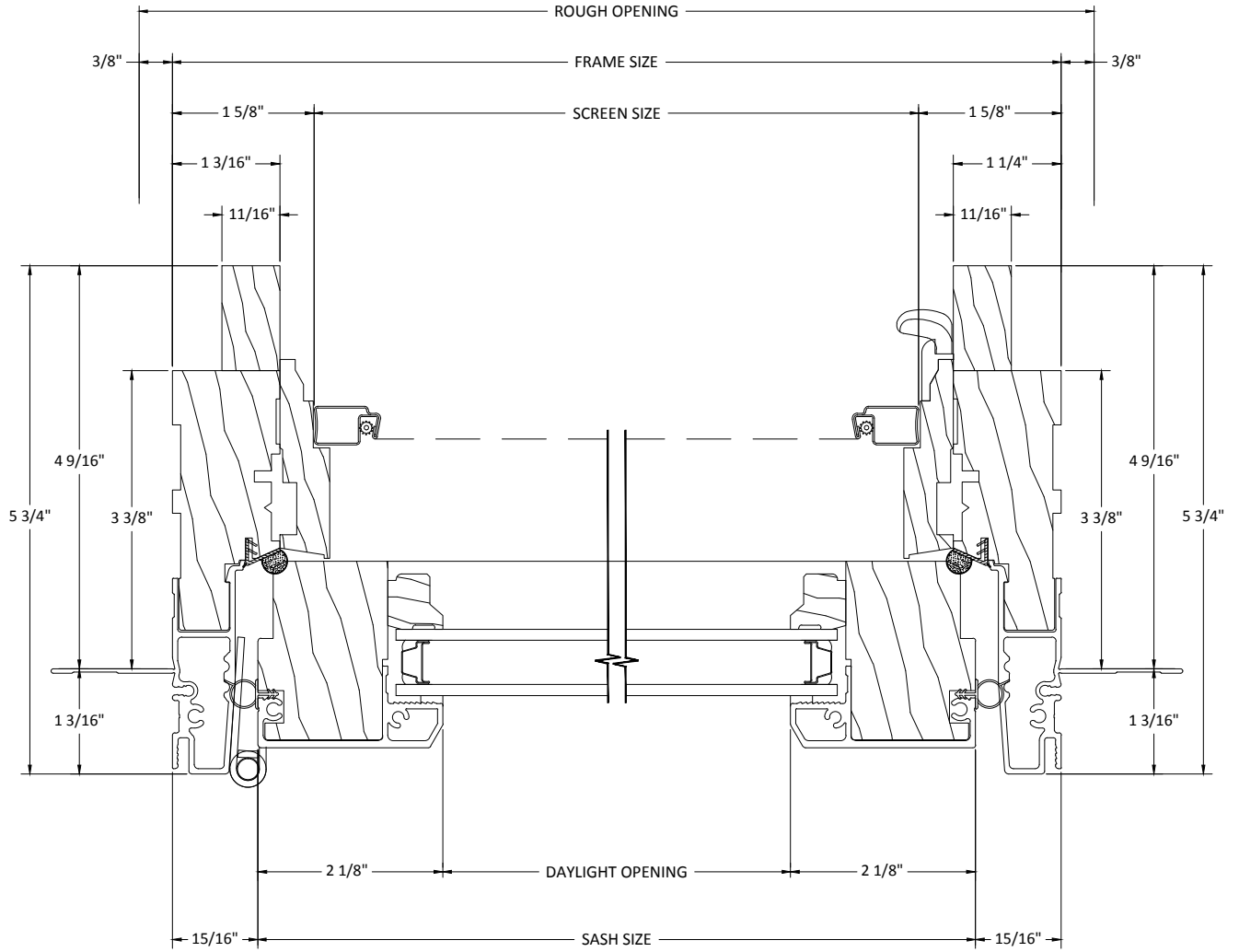

BAY WINDOW HORIZONTAL SPECIFICATION TABLES SECTIONS

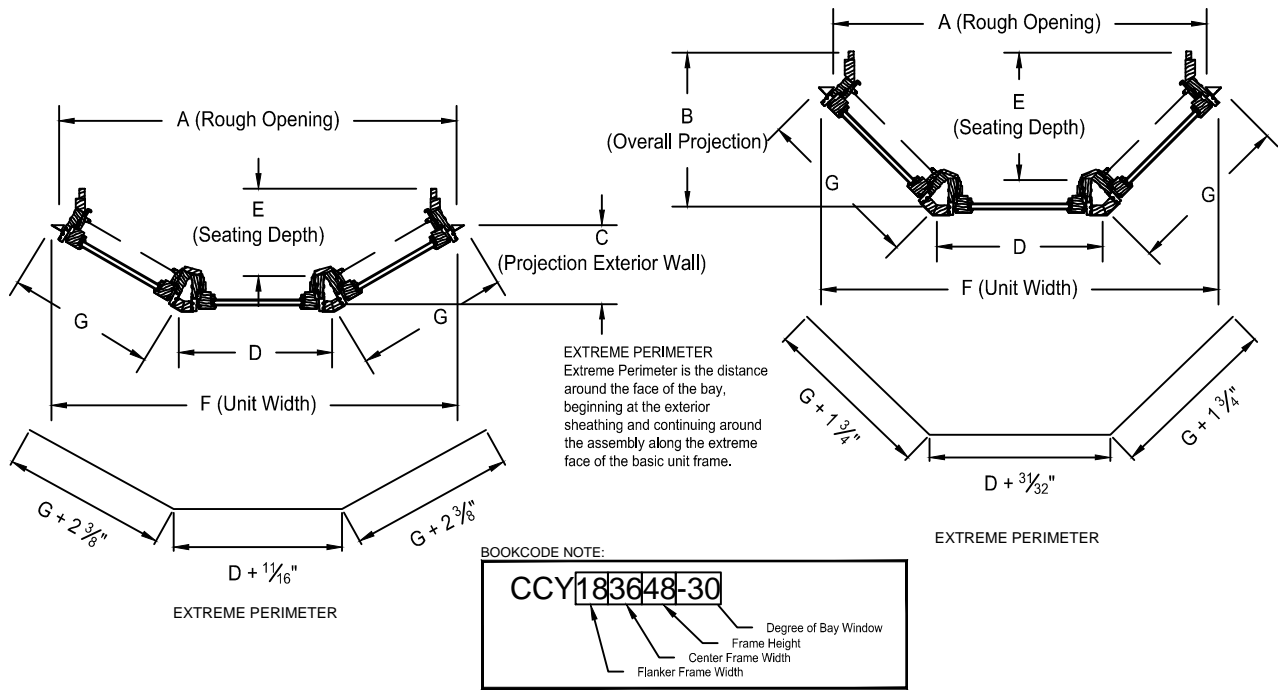

30° BAY									
Flanker Width	Center Width	A Rough Opening	F Unit Width	B* Overall Projection	C Projection Exterior Wall	E* Seating Depth	D Outside Mull To Mull	G Outside Mull To Unit	
18	18	52 3/8	53 11/16	14 13/16	10 1/4	11 7/16	19 13/16	20 3/8	
18	36	70 3/8	71 11/16	14 13/16	10 1/4	11 7/16	37 13/16	20 3/8	
18	42	76 3/8	77 11/16	14 13/16	10 1/4	11 7/16	43 13/16	20 3/8	
18	48	82 3/8	83 11/16	14 13/16	10 1/4	11 7/16	49 13/16	20 3/8	
18	60	94 3/8	95 11/16	14 13/16	10 1/4	11 7/16	61 13/16	20 3/8	
18	72	106 3/8	107 11/16	14 13/16	10 1/4	11 7/16	73 13/16	20 3/8	

24	24	68 13/16	70 1/16	17 13/16	13 1/4	14 7/16	25 13/16	26 3/8	
24	36	80 13/16	82 1/16	17 13/16	13 1/4	14 7/16	37 13/16	26 3/8	
24	42	86 13/16	88 1/16	17 13/16	13 1/4	14 7/16	43 13/16	26 3/8	
24	48	92 13/16	94 1/16	17 13/16	13 1/4	14 7/16	49 13/16	26 3/8	
24	60	104 13/16	106 1/16	17 13/16	13 1/4	14 7/16	61 13/16	26 3/8	
24	72	116 13/16	118 1/16	17 13/16	13 1/4	14 7/16	73 13/16	26 3/8	

28	28	79 11/16	81	19 13/16	15 1/4	16 7/16	29 13/16	30 3/8	
28	36	87 11/16	89	19 13/16	15 1/4	16 7/16	37 13/16	30 3/8	
28	42	93 11/16	95	19 13/16	15 1/4	16 7/16	43 13/16	30 3/8	
28	48	99 11/16	101	19 13/16	15 1/4	16 7/16	49 13/16	30 3/8	
28	60	111 11/16	113	19 13/16	15 1/4	16 7/16	61 13/16	30 3/8	
28	72	123 11/16	125	19 13/16	15 1/4	16 7/16	73 13/16	30 3/8	

45° BAY									
Flanker Width	Center Width	A Rough Opening	F Unit Width	B* Overall Projection	C Projection Exterior Wall	E* Seating Depth	D Outside Mull To Mull	G Outside Mull To Unit	
18	18	46 13/16	49 13/16	19 5/16	14 13/16	15 15/16	20 13/16	20 7/8	
18	36	64 13/16	67 13/16	19 5/16	14 13/16	15 15/16	38 13/16	20 7/8	
18	42	70 13/16	73 13/16	19 5/16	14 13/16	15 15/16	44 13/16	20 7/8	
18	48	76 13/16	79 13/16	19 5/16	14 13/16	15 15/16	50 13/16	20 7/8	
18	60	88 13/16	91 13/16	19 5/16	14 13/16	15 15/16	62 13/16	20 7/8	
18	72	100 13/16	103 13/16	19 5/16	14 13/16	15 15/16	74 13/16	20 7/8	

24	24	61 5/16	64 5/16	23 9/16	19 1/32	20 3/16	26 13/16	26 7/8	
24	36	73 5/16	76 5/16	23 9/16	19 1/32	20 3/16	38 13/16	26 7/8	
24	42	79 5/16	82 5/16	23 9/16	19 1/32	20 3/16	44 13/16	26 7/8	
24	48	85 5/16	88 5/16	23 9/16	19 1/32	20 3/16	50 13/16	26 7/8	
24	60	97 5/16	100 5/16	23 9/16	19 1/32	20 3/16	62 13/16	26 7/8	
24	72	109 5/16	112 5/16	23 9/16	19 1/32	20 3/16	74 13/16	26 7/8	

28	28	71	73 31/32	26 3/8	21 7/8	23	30 13/16	30 7/8	
28	36	79	81 31/32	26 3/8	21 7/8	23	38 13/16	30 7/8	
28	42	85	87 31/32	26 3/8	21 7/8	23	44 13/16	30 7/8	
28	48	91	93 31/32	26 3/8	21 7/8	23	50 13/16	30 7/8	
28	60	103	105 31/32	26 3/8	21 7/8	23	62 13/16	30 7/8	
28	72	115	117 31/32	26 3/8	21 7/8	23	74 13/16	30 7/8	

4 9/16 and 6 9/16 WALL APPLICATION
The tables above reflect a 4 9/16" wall application. To convert to 6 9/16" wall application add 2" to the figures in the columns which show an asterisk (*), B and E.
ROUGH OPENING data reflects FRAME + 3/4".

BOW WINDOW HORIZONTAL SPECIFICATION TABLES

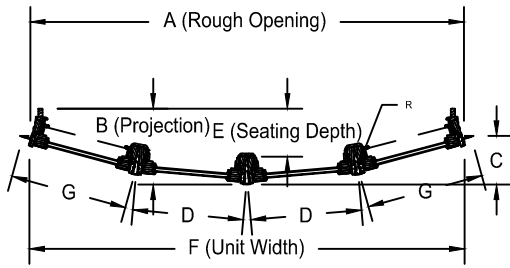

4 WIDE BOW									
Flanker Width	A Rough Opening	F Unit Width	B Overall Projection*	C Projection Exterior Wall	E Seating Depth*	D Outside Mull To Mull	G Outside Mull To Unit	R Radius	
18	72 7/8	72 32/32	11 13/32	6 27/32	8	18 19/32	19 25/32	106 1/2	
24	96 7/16	96 1/2	13 15/32	8 29/32	10 3/32	24 19/32	25 25/32	140 3/8	
28	112 1/8	112 3/16	14 7/8	10 5/16	11 15/32	28 19/32	29 25/32	163 1/16	

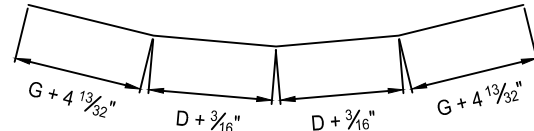

EXTREME PERIMETER
Extreme Perimeter is the distance around the face of the bow, beginning at the exterior sheathing and continuing around the assembly along the extreme face of the brickmould.

EXTREME PERIMETER

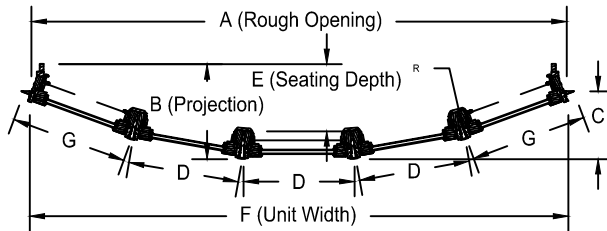

5 WIDE BOW									
Flanker Width	A Rough Opening	F Unit Width	B Overall Projection*	C Projection Exterior Wall	E Seating Depth*	D Outside Mull To Mull	G Outside Mull To Unit	R Radius	
18	89 15/16	90 3/8	14 5/8	10 1/16	11 7/32	18 19/32	19 25/32	106 1/2	
24	119	119 7/16	17 11/16	13 1/8	14 5/16	24 19/32	25 25/32	140 15/16	
28	138 3/8	138 27/32	19 3/4	15 3/16	16 3/8	28 19/32	29 25/32	163 1/16	

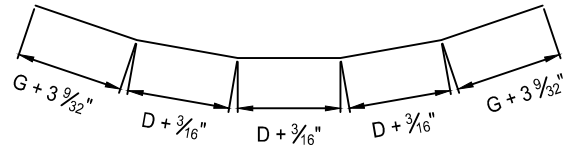

RADIUS NOTE: The Radius of a Bow Window is referenced from the interior of the Brickmould.

EXTREME PERIMETER

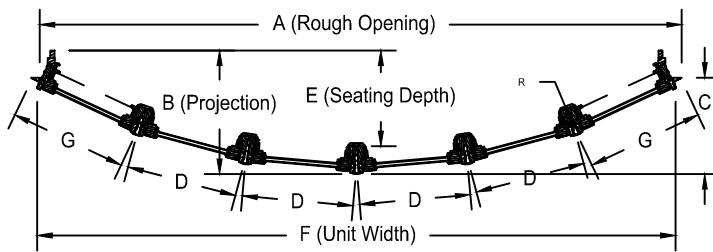

6 WIDE BOW									
Flanker Width	A Rough Opening	F Unit Width	B Overall Projection*	C Projection Exterior Wall	E Seating Depth*	D Outside Mull To Mull	G Outside Mull To Unit	R Radius	
18	106 1/4	107 1/16	19 3/8	14 13/16	16	18 19/32	19 25/32	106 1/2	
24	140 5/8	141 15/32	24	19 7/16	20 5/8	24 19/32	25 25/32	140 15/16	
28	163 5/8	164 7/16	27 1/16	22 1/2	23 11/16	28 19/32	29 25/32	163 1/16	

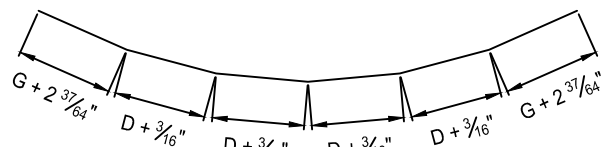

EXTREME PERIMETER

4 9/16 and 6 9/16 WALL APPLICATION
The tables above reflect a 4 9/16" wall application. To convert to 6 9/16" wall application add 2" to the figures in the columns which show an asterisk (*), B and E.

BAY & BOW WINDOW ROUGH OPENINGS

BAY & BOW WINDOW TRIM OPTIONS

The standard offering for clad bay & bow windows is 'frame only' and brickmould and sillnose. Other trim options subject to approval. Rough & Masonry openings remain consistent with all trim options.

VERTICAL ROUGH OPENING

Rough Opening typical for all Units

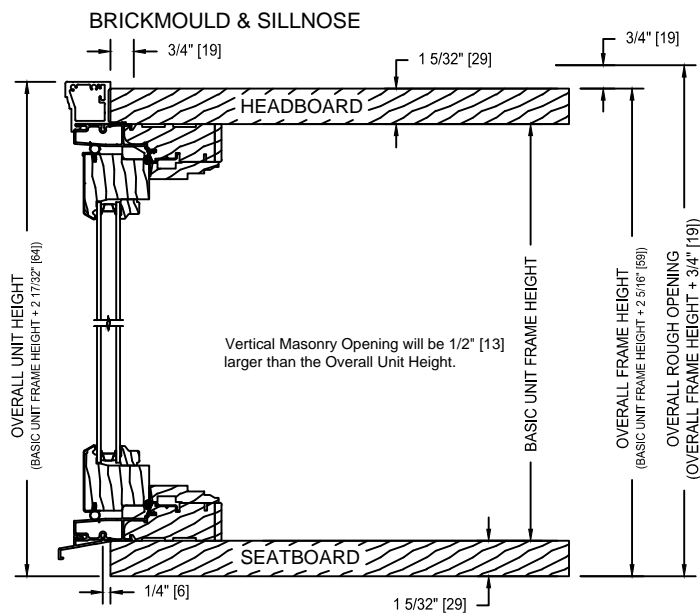
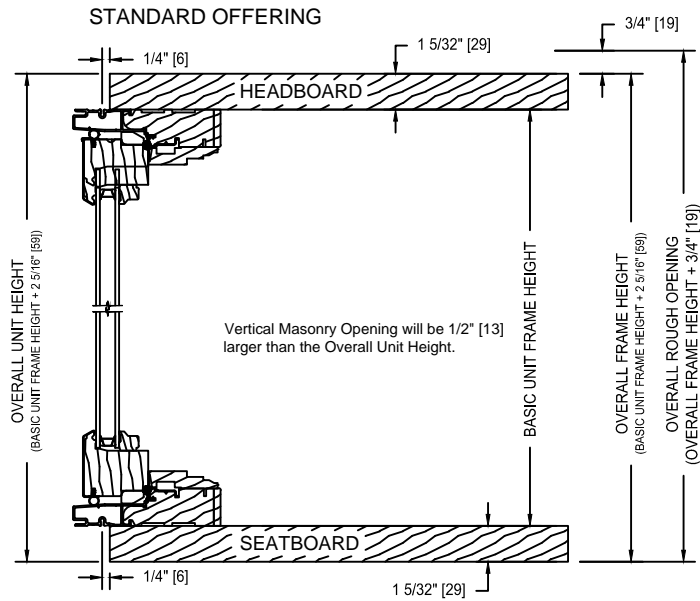

HORIZONTAL ROUGH OPENING

Rough Opening typical for all Units

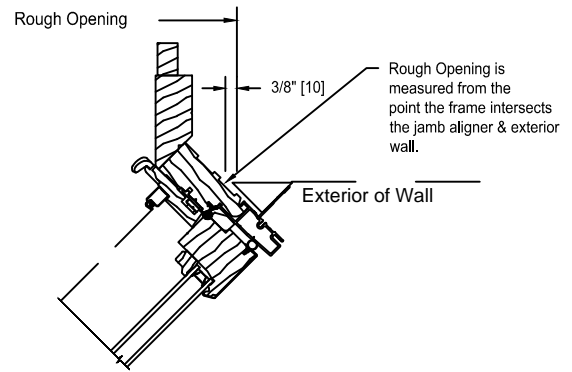

30° & 45° BAYS
45° Bay Shown without trim

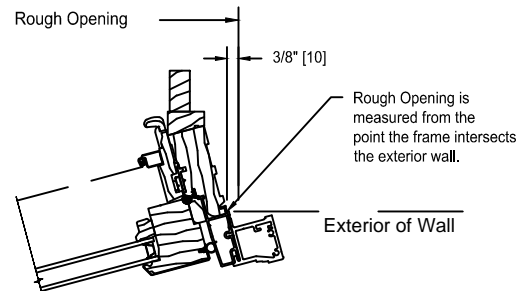

4, 5 & 6 WIDE BOWS
4 Wide Bow Shown with Brickmould Shown

MIN-MAX SIZING

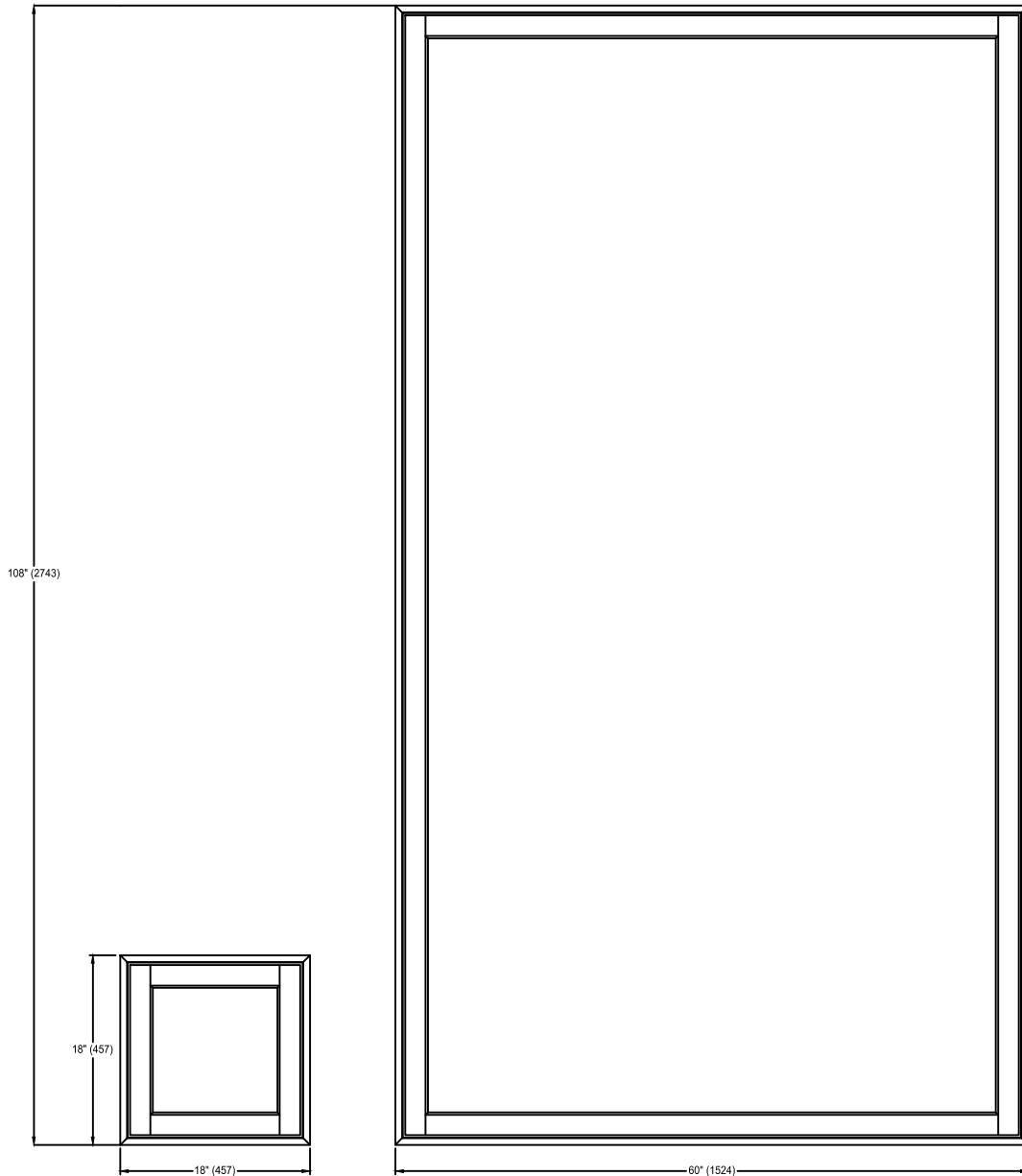

Standard widths for the Custom Clad Epic Casement Window:

18" (457mm), 20" (508mm), 24" (610mm), 30" (762mm), 32" (813mm),
36" (914mm), 40" (1016mm), 42" (1067mm), 38" (1219mm), 54" (1372mm),
56" (1422mm), 60" (1524mm), 64" (1626mm), 66" (1676mm), 72" (1829mm),
78" (1981mm), 84" (2134mm), 90" (2286mm), 96" (2438mm), 102" (2591mm),
108" (2743mm)

Standard heights for the Custom Clad Epic Casement Window:

18" (457mm), 20" (508mm), 24" (610mm), 28" (711mm), 30" (762mm),
32" (813mm), 36" (914mm), 40" (1016mm), 42" (1067mm), 48" (1219mm),
54" (1372mm), 56" (1422mm), 60" (1524mm)

PICTURE MIN-MAX SIZING

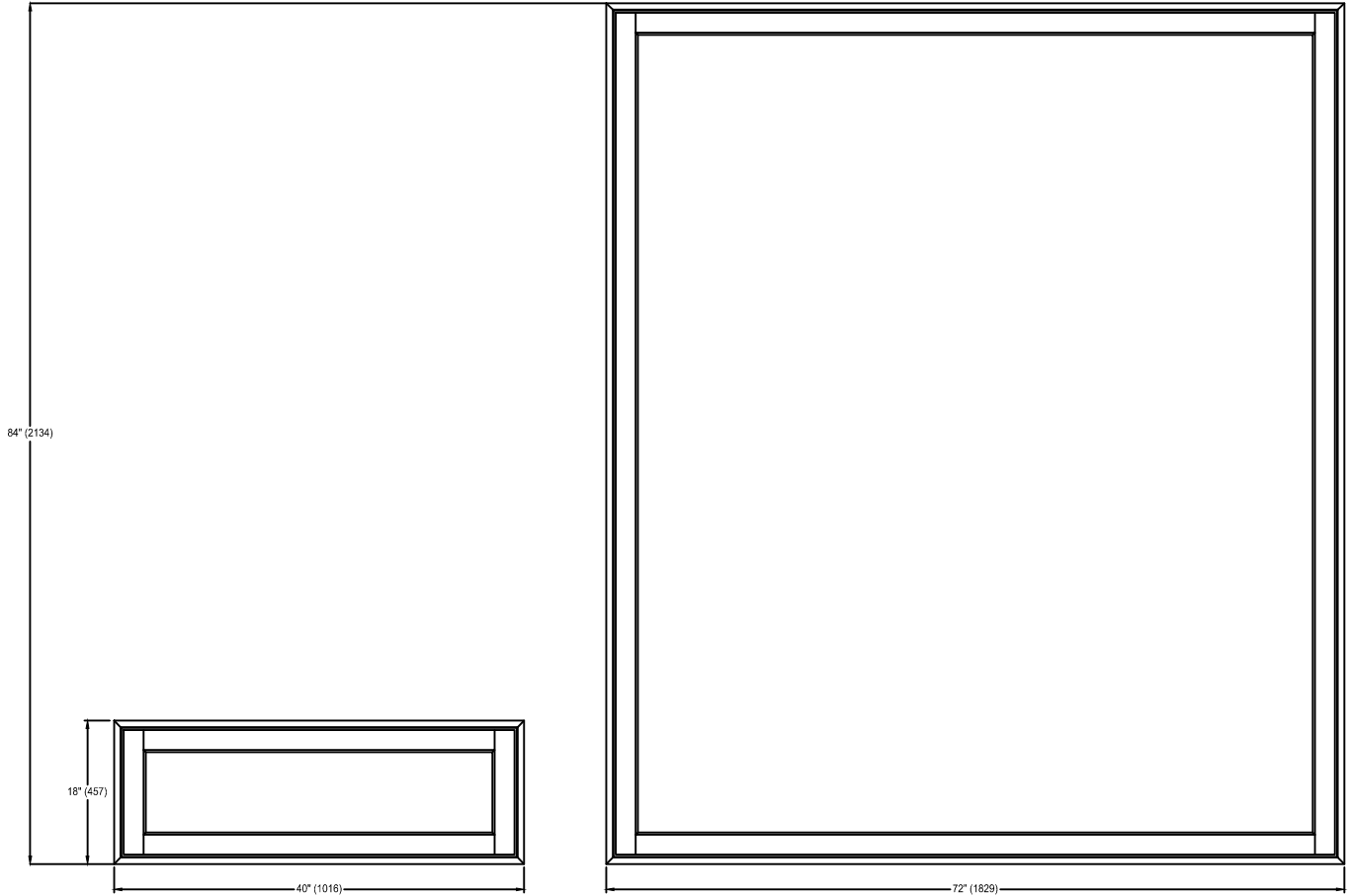

Standard widths for the Custom Clad Epic Casement Picture Window:
40" (1016mm), 42" (1067mm), 48" (1219mm), 54" (1372mm), 56" (1422mm),
60" (1524mm), 64" (1626mm), 66" (1676mm), 72" (1829mm)

Standard heights for the Custom Clad Epic Casement Picture Window:
18" (457mm), 20" (508mm), 24" (610mm), 30" (762mm), 32" (813mm),
36" (914mm), 40" (1016mm), 42" (1067mm), 48" (1219mm), 54" (1372mm),
56" (1422mm), 60" (1524mm), 64" (1626mm), 66" (1676mm), 72" (1829mm),
78" (1981mm), 84" (2134mm)